

\$3.00

1949 TO 1953

CARS

2012-13



Technical Questions

517-676-4416

Orders Only

800-728-0762

WWW.YESTERYEARFORDPARTS.COM



David Groh
Fax 517-676-3485

4322 Curtice Rd.
Mason, MI 48854

INFORMATION

BUSINESS HOURS:

8:00 am to 5:00 pm Monday through Friday,
Saturday by appointment only and, closed Sunday.

PHONE ORDERS:

You must have the part number(s) to place an order.
Phone orders are accepted Monday through Friday
between 8:00 am to 5:00 pm. We are often available
on Saturdays. **ORDERS ONLY 800-728-0762**
Technical questions 517-676-4416
(NO COLLECT CALLS.)
24 Hour Fax Ordering 517-676-3485

.....

SHIPPING, INSURANCE AND HANDLING COSTS:

The following charges are for items shipped in the
United States (except Alaska, Hawaii and foreign
orders.) **Minimum shipping \$10.00.**

\$0-30.00.....add \$10.00 for shipping

\$30.01-50.00.....add \$9.00 for shipping

\$50.01 and upadd 9% for shipping

Small orders can be mailed to save you on shipping.
**Large light items will have oversize charges added
which can significantly increase the cost.**

PAYMENT:

Yesteryear Ford Parts accepts checks, money orders,
Visa, Mastercard, Discover and C.O.D. (cash on
delivery).

There is a \$11.00 charge for C.O.D. orders.

PRICES:

We try to maintain prices as listed but due to the
rapidly changing market, we reserve the right to
change prices without notice.

SALES TAX:

All items picked up at the store or shipped to an
address within Michigan are subject to 6% sales tax.

TRUCK ORDERS:

Parts too large for U.P.S. will be shipped by truck
freight collect. All truck orders must be paid for in
advance, no C.O.D. orders.

RETURNED ITEMS:

We will replace any defective parts or parts shipped
in our error. All other returns must be returned within
30 days of the shipping date. The returned parts are
subject to a 15% restocking charge. All returned items
must include a copy of the original invoice.

NO RETURNS AFTER 30 DAYS.

INDEX

Accelerator pedal	30
Airvent system	46
Anti-squeek material	42
Armature	30
Automatic transmission kit	22
Backup light parts	39
Battery	13
Battery cables	13
Body mount kit	12
Body side moulding clips	43
Books	1
Brake drum	2
Brake parts	4-6
Bumper parts	44-45
Camshaft	16-17
Carburetor kit	29
Choke cable	30
Clutch disc	24
Clutch parts	24-25
Coil	32
Convertible seals	59
Cooling system	25-27
Cowl kick panels	48
Cowl lacing	43
Dash knobs	49-50
Differential bearings	11
Dimmer switch	33
Dipstick	19

Distributor parts	32-33
Dome light	38
Door lock/ignition cylinder	32
Door panel clips	54
Door parts	52-56
Door seals	52
Drag link	9
Engine parts	15-22
Exhaust deflectors	13
Exhaust manifold gaskets	12
Exhaust parts	12-13
Fan belt	27
Fender parts	42-43
Firewall parts	48
Flasher unit	35
Floor pans	60
Floor parts	51
Floor seals	10
Front end parts	7-10
Fuel pump	29
Fuel system	27-30
Gas cap	27
Gas door spring	28
Gas tank sealer	29
Generator parts	30-31
Glove box and parts	51
Grill & hardware	51
Header bow seals	50

INDEX

Headlight parts	33-34
Heater parts	46
Horn button	10
Horn relay	39
Hood parts	43-44
Hood bumpers	44
Hub caps	2
Idler arm	9
Intake manifold gasket	18
Ignition cylinder/door lock	32
Ignition parts	32-33
Ignition wires	32
Key blanks	10
King pins	9
Knobs	49
Lenses	38
License bracket	36
License light	36
Light bulbs	33
Lock button	52
Master cylinder	6
Motor mounts	15
Muffler	12
Mirror	45
Oil pan gasket	19
Oil pressure sending unit	18
Outside door handles	55-56
Paint and chemicals	60-61

Parking lights	34-35
Pedal pads	6
Pinion bearings	11
Pistons	16
Pressure plate	25
Quarter window seals	55
Radiator cap	25
Radiator hoses	26
Radio parts	47
Rear axle parts	11-12
Rear window seals	57
Ring gear	17
Scuff plates	52
Sending unit (gas tank)	29
Shock absorbers	45
Spark plugs	33
Speed equipment	19-22
Speedometer cable	44
Spring/rear	14-15
Starter	31-32
Stainless body trim	60
Steering box parts	10
Stop light switch	33
Sunvisors	48
Taillights	36-38
Taillight rim	38
Throwout bearing	24
Tie rod ends	9

INDEX

Transmission	22-24
Transmission mounts	15
Trunk parts	57-58
Trunk hinges	57
Turn signal knob	35
Universal joint	11
Valves	17
Vent window seals	54-55
Voltage regulator	30
Water pumps (new)	27
Water pump rebuild kit	27
Wheel bearing	3
Wheel parts	2-3
Wheel trim rings	2
Windshield seals	50
Wiper parts	45
Wiring	39-42
Wiring Illustration (Basic parts) ..	37

**Yesteryear Ford Parts
also stocks parts for 1932-48
Ford cars and 1932-56 Ford
trucks**

BOOKS

Shop Manual

This is an in-depth manual from brakes to window installation. There are hundreds of illustrations with detailed information on rebuilding all mechanical, assembly and adjustments of the body.

LVF	1949-51	48.00 ea.
LVG	1952-54	50.00 ea.

Wiring Diagram Manual

MP-113	1949-51	5.00 ea.
MP-114	1952-54	5.00 ea.

Radio Instruction Books

RB-49	1949 cars	4.00 ea.
RB-50C	1950 custom	4.00 ea.
RB-50D	1950 deluxe	4.00 ea.
RB-51C	1951 custom	4.00 ea.
RB-51D	1951 deluxe	4.00 ea.
RB-52	1952	4.00 ea.
RB-53	1953	4.00 ea.

Body Parts

1944-52 Body Parts Book

This is a copy of the original parts book. It contains many illustrations and all the body part numbers. This is a very valuable book when identifying parts.

LV-44	50.00 ea.
-------	-----------

Operators Manuals

These books are reprints of the original book that came in the glove box of each new car. They cover all the basic operations of the various parts of the car.

LV50	1950	operators manual	10.00 ea.
LV51	1951	operators manual	10.00 ea.
101521	1952	operators manual	10.00 ea.
101531	1953	operators manual	10.00 ea.

Most orders shipped same day!

We accept



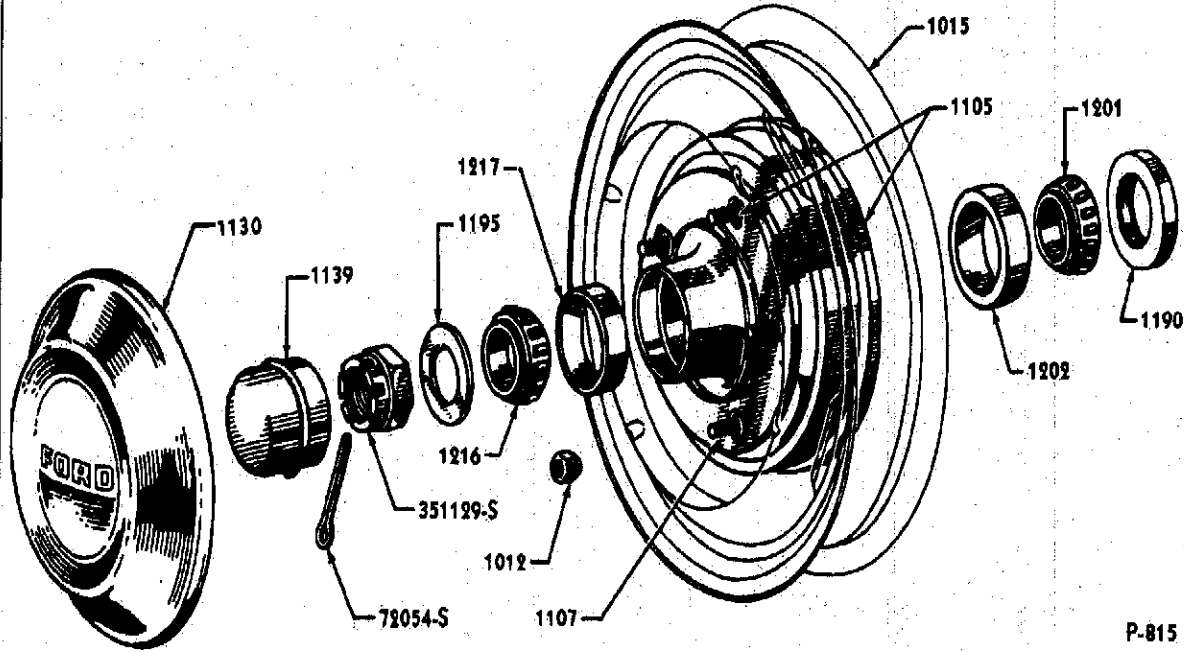

FRONT WHEEL, HUB, BEARINGS, ETC.

P-815

USE FOR BASIC PART NUMBERS ONLY.

WHEEL BOLTS, NUTS, BEARINGS AND SEALS

Wheel Bolt and Nut

B-1012	1932-60	wheel nut	.80 ea.
8A-1107	1948-60	hub bolt	2.50 ea.

Brake Drums

OA-1125	1949-53	front cars	95.00 ea.
AB-1126	1949-53	rear cars	95.00 ea.

Hub Caps

These caps are stainless steel duplicates of the originals.

8A-1130	1949-50	Ford cars	35.00 ea.
1A-1130	1951	Ford car	35.00 ea.

Trim Rings (stainless steel)

8A-18303-15	1949-53 convex smooth trim ring		35.00 ea.
-------------	---------------------------------	--	-----------

Front Hub Grease Cap

51A-1139	1940-54	Ford car	1.93" press on type	3.00 ea.
----------	---------	----------	---------------------	----------

Rear Axle Shaft Plate Gasket

8A-2245	1949-52	Ford cars		3.00 ea.
---------	---------	-----------	--	----------

Rear Wheel Seals

8A-1177	1949-56	Ford car	4.50 ea.
0M-1177	1948-56	wagon and Mercury	5.00 ea.

Front Wheel Seals

8A-1190	1949-53	Ford/Mercury 2.62" o.d.	5.00 ea.
---------	---------	-------------------------	----------

Front Spindle Washer

B-1195	1949-56	car	2.00 ea.
--------	---------	-----	----------

Rear Axle Bearing at Wheel

8A-1225	1949-56		27.50 ea.
---------	---------	--	-----------

Rear Wheel Bearing Retainer

This is the steel ring that keeps the bearing in place.

8A-1180	1949-60		9.00 ea.
---------	---------	--	----------

FRONT WHEEL BEARINGS

Front Wheel Bearings Ford Cars

These are for cars with 2.62" standard hubs.

8A-1201	1949-54	inner bearing	17.00 ea.
8A-1202		inner race	7.50 ea.
8A-1216		outer bearing	17.00 ea.
8A-1217		outer race	8.50 ea.

Front Wheel Bearings Mercury

8A-1201	1949-51	inner bearing	17.00 ea.
8A-1202	1949-51	inner race	7.50 ea.
8M-1216	1949-51	outer bearing	13.50 ea.
8M-1217	1949-51	outer race	6.50 ea.

**WE REBUILD GENERATORS, STARTERS, DISTRIBUTORS,
ENGINES, TRANSMISSIONS, RELINE BRAKE SHOES AND
TURN BRAKE DRUMS.**

TOP QUALITY SERVICE !

Most orders shipped same day!

We accept



BRAKE PARTS

Relined Brake Shoes

1949-54 Ford cars sold in axle sets.

154-2001		fronts	30.00 set
151-2001		rears	30.00 set
228-2001	1949-54 mercury front		30.00 set

Master Cylinder Kits

This includes all the rubber seals and pistons needed to rebuild your master cylinder.

A9A-2004	1949-51	Ford cars	14.00 kit
8M-2004	1949-51	Mercury	12.00 kit
B5A-2004	1952-64	with std. brakes	14.00 kit

Brake Shoe Return Spring

8A-2035	1949-54	front or rear	2.50 ea.
---------	---------	---------------	----------

Brake Adjusting Screw Spring

8A-2049	1949-54	front or rear	4.50 ea.
---------	---------	---------------	----------

Front Brake to Hose Elbow

8A-2075	1949-54 left brake brass block		8.00 ea.
---------	--------------------------------	--	----------

Brake Adjusting Hole Rubber Plug

8A-2092	1949-70	all	.80 ea.
---------	---------	-----	---------

Brake Shoe Hold Down Kits

Each kit has enough parts for two brake plates (includes pins, spring, and washers etc.)

19472-2A094	1949-54	all cars	11.00 set
-------------	---------	----------	-----------

Front Wheel Cylinders

AD-2061	1949-57 Ford, 49-54 Merc.	right hand front	30.00 ea.
AD-2062	1949-57 Ford, 49-54 Merc.	left hand front	30.00 ea.

Rear Wheel Cylinders

8A-2261	1949-64	right rear	26.00 ea.
8A-2262	1949-64	left rear	26.00 ea.

Wheel Cylinder Repair Kits

8M-2221	1949-64	fronts	5.00 kit
8A-2128	1949-64	rears	5.00 kit

Rear Backing Plate Gasket

8A-2256	1949-51	cars	1.00 ea.
---------	---------	------	----------

Wheel Cylinder Bleeder Screw

8M-2208	1939-64	cars	1.50 ea.
---------	---------	------	----------

Rear Brake Pipe Brass Connecting Block

This mounts on rear axle and T's off lines to each rear brake.

8A-2074	1949-56	car	8.00 ea.
---------	---------	-----	----------

Most orders shipped same day!

We accept



Front and Rear Brake Hoses

8A-2079	1949-53	front hose	18.00 ea.
8A-2078	1949-51	rear hose	20.00 ea.
AB-2078	1952-53	rear hose	18.00 ea.

New Master Cylinders

A9A-2140	1949-51	std. brakes	125.00 ea.
B5A-2140	1952-60	std. brakes	95.00 ea.

Master Cylinder Push Rod

8A-2143	1949-51	Ford cars	7.00 ea.
---------	---------	-----------	----------

Filler Cap for Master Cylinder

1A-2162	1949-51	cars	11.00 ea.
AB-2162	1952-59		8.00 ea.

Master Cylinder Floor Cover Plate

91A-7011136	1939-53		7.50 ea.
-------------	---------	--	----------

Master Cylinder Rubber Boot

0A-2180	1949-60	cars	3.50 ea.
---------	---------	------	----------

Brake Line

8C-2269-B	1949-53 3/16" line in a 25 ft. roll		25.00 roll
-----------	-------------------------------------	--	------------

Brake Line Kits

The lines in these kits are all prebent, stainless steel and ready to install. Hoses not included.

8A-2269-KIT	1949-50 cars		175.00 kit
1A-2269-KIT	1951 cars		175.00 kit
FAA-2269-KIT	1952-53 cars		175.00 kit
8M-2269-KIT	1949-51 Mercury		175.00 kit

Brake Cable

8A-2275-C	1949-51 cars rear		40.00 ea.
8A-2853-C	1949-50 front hand brake cable		35.00 ea.
B5A-2853-D	1952-56 car front hand brake cable		37.50 ea.

Brake Hose Clip

78-2814	1949-64	all	1.10 ea.
---------	---------	-----	----------

Brake and Clutch Pedal Pads

1A-2454-A	1949-51	Ford with std. transmission	6.50 ea.
AB-2454-B	1952-67	brake pedal auto. transmission	12.00 ea.
AB-2454	1952-56	rubber pedal cover	6.00 ea.

Bushing (Pedal bushing at master cylinder)

8A-2470	1949-51 (2 required) all Ford cars		5.00 ea.
---------	------------------------------------	--	----------

Clutch and Brake Pedal Floor Seals

8A-2476-A	1949-51	Ford cars	5.00 pr.
-----------	---------	-----------	----------

Hand Brake Cable Grommet at Firewall

0A-2273	1949-50	cars	12.50 ea.
---------	---------	------	-----------

Brake Pedal Spring

8A-2456	1949-51 Ford		6.50 ea.
---------	--------------	--	----------

FRONT END/ SUSPENSION PARTS

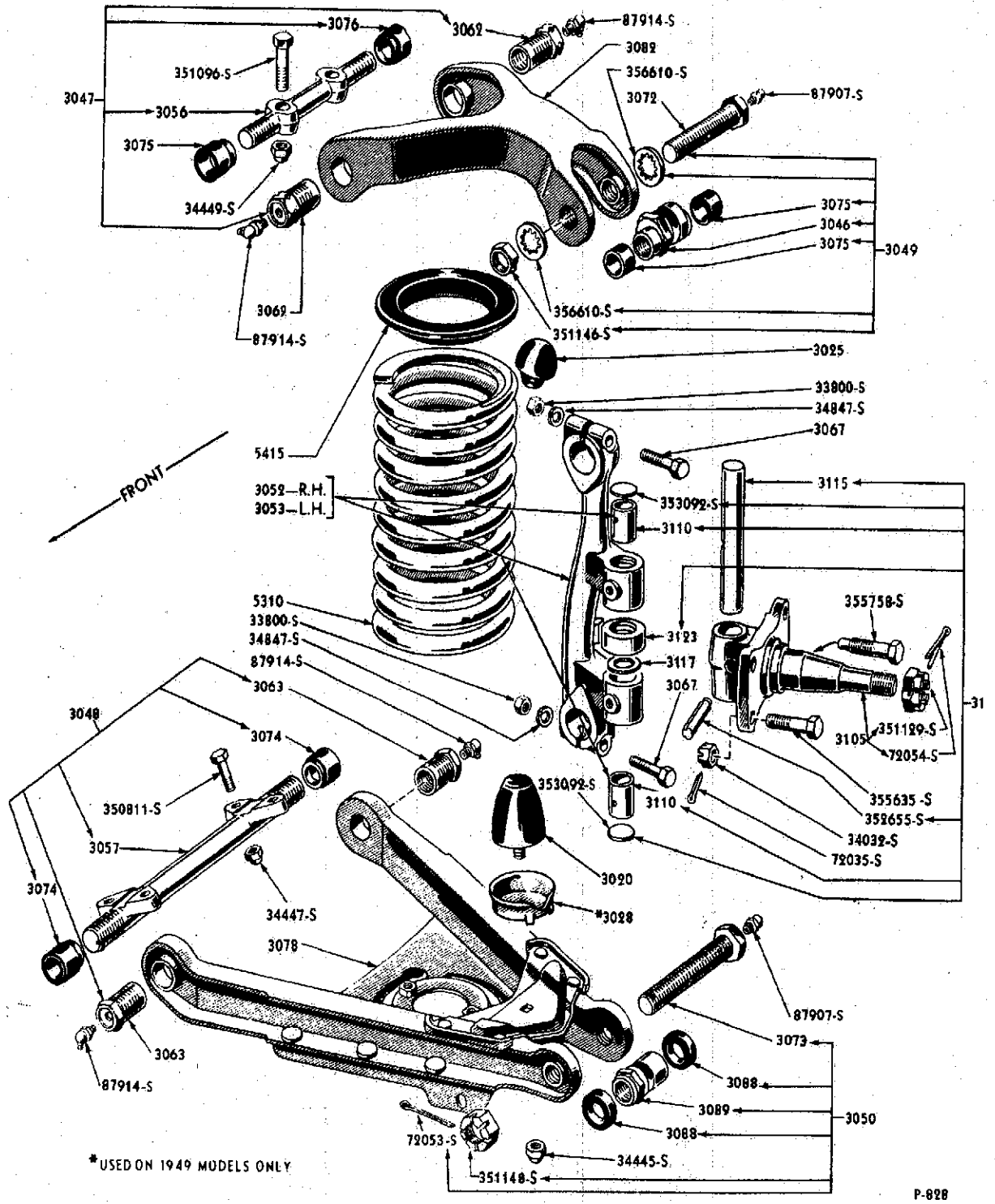

USE FOR BASIC PART NUMBERS ONLY

Most orders shipped same day!

We accept



STEERING GEAR AND STEERING LINKAGE

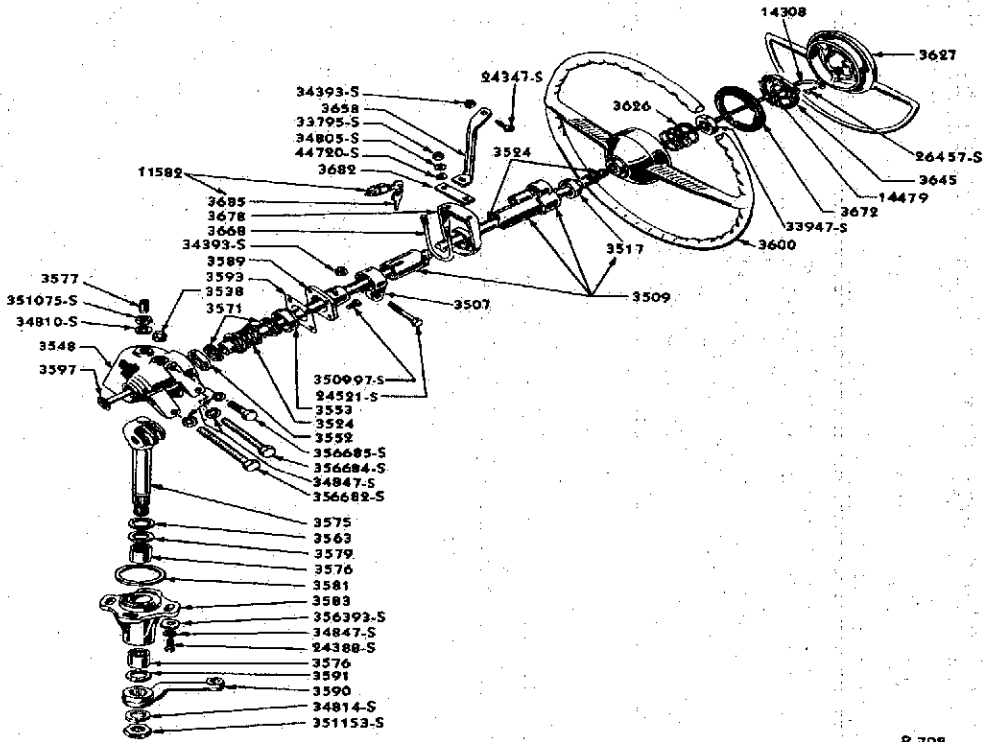

P-708

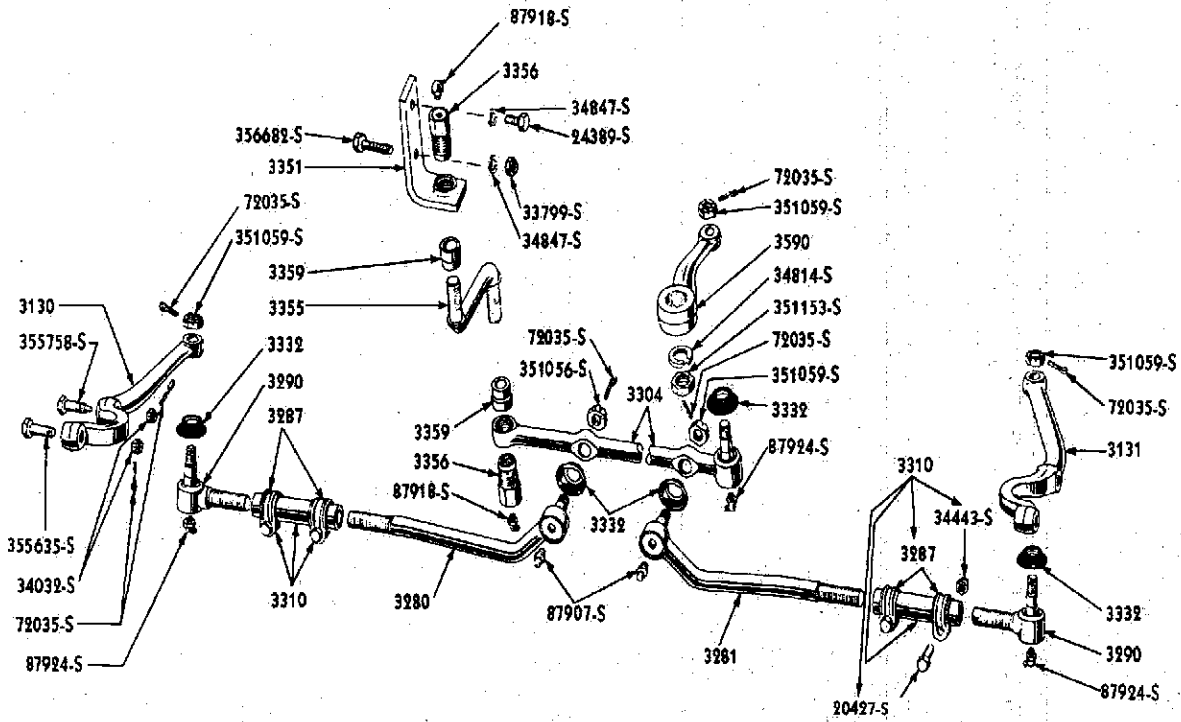

USE FOR BASIC PART NUMBERS ONLY

FRONT END/ SUSPENSION PARTS

Front Stabilizer Parts

8A-5493	1949-51 stabilizer bar rubber bushings (4 required)	3.00 ea.
AB-5943	1952-53 stabilizer bar rubber bushings	6.00 ea.

Lower A Frame Support Rubber Bumper

AB-3019	1949-52 main bumper cars	6.00 ea.
8A-3025	1949-53 rebound insulator	3.50 ea.

Individual Seals From the Above Kits

8M-3074	Inner lower arm seal	4 per car	2.00 ea.
8A-3075	upper inner seal	4 per car	2.00 ea.

Upper and Lower Spindle Kits

8A-3049	outer upper kit	1949-53	38.00 kit
8A-3050	outer lower kit	1949-53	35.00 kit
8A-3047	inner upper A-frame pivot kit	49-53 car	40.00 kit
8A-3048	lower inner A-frame pivot kit	1949-53 car	40.00 kit

Complete King Pin Kits

Kits include pins, bushings, seals and bearings.

8A-3111	1949-53	Ford	55.00 kit
8M-3111	1949-51	Mercury	65.00 kit

Spindle Arms

AB-3130	1952-53	R.H. Ford cars	25.00 ea.
AB-3131	1952-53	L.H. Ford cars	25.00 ea.

Tie Rod Ends

11A-3270	1949-59	Ford outer	15.00 ea.
8A-3280	1949-51	inner R.H.	37.50 ea.
8A-3281	1949-51	inner L.H.	37.50 ea.
AB-3280	1952-53	R.H. or L.H. inner	39.00 ea.

Tie Rod Coupling Sleeve

11A-3310	1949-65	all cars	14.00 ea.
----------	---------	----------	-----------

Tie Rod End Rubber Seal

8M-3332	1949-59	all cars	1.00 ea.
---------	---------	----------	----------

Center Drag Link

8A-3304	1949-51	Ford	60.00 ea.
AB-3305	1952-53	with manual steering	60.00 ea.

Drag Link Internal Parts Kit

B2AZ-3533-A	1952-59	ball and parts kit	35.00 kit
-------------	---------	--------------------	-----------

Idler Arm Support Bracket

8A-3351	1949-59	Ford cars with manual steering	10.00 ea.
---------	---------	--------------------------------	-----------

Most orders shipped same day!

We accept



Idler Arm Rebuild Kit

Includes idler arm plus bushings and seals.

A9A-3352	1949-51	Ford	car w/manual steering	25.00 kit
B2A-3352	1952-53	Ford	car w/manual steering	25.00 kit
8M-3352	1949-51	Mercury	w/manual steering	40.00 kit

Idler Arm Seals

These are part of the above 3352 kits.

8M-3359	2 needed per car			3.00 ea.
---------	------------------	--	--	----------

Steering and Pedal Floor Seal

8A-3512	1949-51	clutch arm to floor plate seal		2.00 ea.
8A-3513	1949-51	steering tube to floor seal (std. trans.)		6.00 ea.

Steering Shaft and Worm Gear

8A-3524	1949-50	all cars		125.00 ea.
1A-3524	1951	Ford cars		125.00 ea.
AB-3524	1952-53	Ford cars		125.00 ea.

Worm Gear Bearings and Races

These are for both Ford and Mercury.

B-3552	lower race	1949-57 Ford & Merc.		12.00 ea.
8A-3553	upper race	1949-57 Ford & Merc.		22.00 ea.
68-3571	upper and lower bearing	1949-57 Ford & Merc.		9.00 ea.

Sector Shaft Roller Bearings

68-3576	1949-56	all cars		10.00 ea.
---------	---------	----------	--	-----------

Steering Box Gasket Set

8A-3581	1949-51	cars		8.00 set
AB-3581	1952-57	cars		7.50 set

Sector Shaft Oil Seal

8A-3591	1949-56	cars		3.00 ea.
---------	---------	------	--	----------

Pitman Arm

This is the arm attached to the sector shaft.

8A-3590	1949-51	cars		40.00 ea.
---------	---------	------	--	-----------

Horn Button Inserts

Plastic inserts for the center of the horn ring. exact reproductions.

8A-3627	1949			40.00 ea.
0A-3627	1950			40.00 ea.
FAD-3627	50th Anniversary			35.00 ea.

Horn Button Insulator

0A-3672	1949-50 cars			4.00 ea.
---------	--------------	--	--	----------

Key Blanks (These are made exactly as original)

8A-3685-A	1949-50	ignition and door		4.00 ea.
8A-3685-B	1949-50	trunk and glove box		4.00 ea.
1A-3685-A	1951	ignition and door		4.50 ea.
1A-3685-B	1951	trunk and glove box		4.50 ea.
BA-3685-ANV	1952-64	anniversary blank		10.00 ea.

Crossover Pipe Gasket

C1SZ-9450	1949-62 V-8	2.50 ea.
-----------	-------------	----------

Stainless Steel Exhaust Deflectors

This keeps the exhaust off the chrome bumper.

51A-18529-A	stamped with Ford script	18.00 ea.
51A-18529-B	stamped with V-8 symbol	18.00 ea.
51A-18529-P	plain no symbols	15.00 ea.
8A-18259-SS	original for 1949-55	50.00 ea.

Exhaust Paint

This is Bill Hirsch's best manifold paint. 1800° F. Soft, silky finish. Long lasting, easy to apply.

EMPT-16	black, pint can	28.00 pint
EMPT-14	cast iron, pint can	27.00 pint
EMPT-15	aluminum, pint can	27.00 pint
EMPT-03	stainless steel, 1600° F	21.00 pint

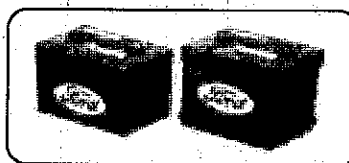
BATTERY**1949-53 Ford Script Battery**

This 6 volt battery has a 4 year pro-rated warranty.

Dimensions are (top of post) 10-1/4" L x 7-1/8" W x 9-1/4"H.

2HF-O	Optima in Ford script case	310.00 ea.
-------	----------------------------	------------

Battery Cables

These cables are Ford script show quality and very nice.

8A-14300	1949-51 battery to solenoid	20.00 ea.
8A-14431	1949-51 starter to solenoid	25.00 ea.

Non Script Cables

8A-14301-NS	49-53 ground	14.00 ea.
8A-14300-NS	49-53 battery to solenoid	13.50 ea.
8A-14331	49-53 solenoid to starter	16.00 ea.

Battery Box

8M-5154-B	1949-51 ford & mercury cars, exact reproduction	70.00 ea.
BA-5154-B	1952-53 Ford cars	75.00 ea.

Battery Hold Down Parts Ford and Mercury

51A-17526	1942-53 battery hold down bracket	20.00 ea.
8M-5175-AS	battery hold down clamp kit for 1949-53. includes nuts, rubber washers, metal washers and 5-1/4" long clamp bolts	10.00 kit

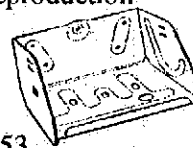

8M-5175	This is the same kit as above but with 3-3/4" hold down bolts.	10.00 kit
---------	---	-----------

Most orders shipped same day!

We accept



Rear Spring U-Bolt

This bolt attaches the rear spring to the axle.

MA-5705-F 1949-56 4 per car 6.00 ea.

Rear Spring Anti-Squeak PadsAB-5586-A 1949-53 These pads go between the spring leaves,
12 required on cars and 16 on wagon and delivery.

3.00 ea.

Front Coil Springs USA made

8A-5310-D 1949-50 closed cars

200.00 pr.

1A-5310-A 1951 closed cars

200.00 pr.

Front Coil Spring Insulators

These are the rubber pads that are located at the top of the spring.

8A-5415-A 1949-53 all 7.50 ea.

ENGINE SECTION**Engine Paint**

8A-6000 1949-51 bronze can be brushed or sprayed on 33.00 quart

FAA-6000 1952-53 orange can be brushed or sprayed on 34.00 quart

Front Motor Mounts

8BA-6038 1949-53 Ford, 52-53 Mercury two per car 15.00 ea.

Rear Transmission Mounts

8A-6068 1949-50 Ford 18.00 ea.

AD-6068 1951-56 Ford 18.00 ea.

Complete Engine Overhaul Gasket Sets

This includes all the gaskets needed for an engine overhaul.

8BA-6008 1948-53 239 v-8 85.00 set

Head Gaskets

EAB-6051 R.H. 239 v-8 26.50 ea.

EAB-6083 L.H. 239 v-8 26.50 ea.

Gasket, Front Timing Cover

8BA-6020 1948-53 239 v-8 2.00 ea.

Fuel Pump Push Rod Bushing

This is a must to replace when overhauling.

8BA-6025 1948-53 239 v-8 5.00 ea.

Valve Seat Insert Ring

This can also be used on the intake valves.

40-6057-B 1.633 o.d. Original 1948-53 239 v-8 2.50 ea.

SB1625-1 1.625 o.d. Use when cutting new hole for hard seat 2.75 ea.

Most orders shipped same day!

We accept.



Cylinder Head Bolts

8BA-6065	1.94"	239 v-8 1948-53	20 per engine	1.50 ea.
8BA-6066	2.62"	239 v-8 1948-53	28 per engine	1.75 ea.

Piston and Pin Sets (sold in sets only, includes pins and keepers)

8BA-6108-STD	1948-53	239 v-8	available in the following sizes: std., 020, 030, 040, 060, 080.	275.00 set
8BA-6108-020	.020 over			275.00 set
8BA-6108-030	.030 over			275.00 set
8BA-6108-040	.040 over			275.00 set
8BA-6108-060	.060 over			275.00 set
8BA-6108-080	.080 over			275.00 set

EAC-6108-STD	standard	255 v-8 Mercury 1949-53	available sizes:	350.00 set
EAC-6108-020	.020 over		std., 020, 030, 040, 060	350.00 set
EAC-6108-030	.030 over			350.00 set
EAC-6108-040	.040 over			350.00 set
EAC-6108-060	.060 over			350.00 set

Piston Wrist Pins

49T-6135	1948-53	239 v-8		2.50 ea.
----------	---------	---------	--	----------

Piston Ring Sets

8BA-6149-STD	standard	1948-53	239, 255 v-8 available sizes: std., 020, 030, 040, 060, 080.	85.00 set
8BA-6149-020	.020 over			85.00 set
8BA-6149-030	.030 over			85.00 set
8BA-6149-040	.040 over			85.00 set
8BA-6149-060	.060 over			85.00 set
8BA-6149-080	.080 over			85.00 set

Connecting Rod Bushings

21A-6207		239 v-8	1948-53	2.00 ea.
----------	--	---------	---------	----------

Pal Nut for Connecting Rod

PF-576		set of 16 Ford and Merc. V-8		2.00 set
--------	--	------------------------------	--	----------

Rod Bearings (sold in pairs)

0BA-6211-010		1948-53	239, 255 v-8 available sizes: std., 010, 020, 030	30.00 per rod
0BA-6211-020		sold in pairs		
0BA-6211-030				

Reground Camshaft

8BA-6250	1949-53 ford	exchange required		100.00 ea
----------	--------------	-------------------	--	-----------

Camshaft Bearings

01A-6260-S	1940-53	239 v-8		25.00 set
------------	---------	---------	--	-----------

Camshaft Small Gear

18-6254-B		oil pump end	239 v-8	16.00 ea.
7RA-6255		distributor drive gear	v-8	16.00 ea.

Camshaft Timing Gears

8BA-6256-F	239, 255	v-8 fiber		55.00 ea.
8BA-6256-A	aluminum			62.00 ea.

Camshaft Gear Lockring				
91A-6258	locking	1939-53		5.00 ea.
Crankshaft Timing Gear				
8BA-6306	239 v-8	1948-53		40.00 ea.
Crankshaft Oil Slinger				
81A-6310	239 v-8	1948-53		2.50 ea.
Crankshaft Plug				
8BA-6307	1948-53 Ford crankshaft only 4 required			1.25 ea.
Pulley Extension				
This is the sleeve behind the pulley that the front seal rides on.				
8BA-6362	1948-53	239 v-8		4.00 ea.
Crankshaft Main Bearings		1948-53 239/255 v-8		
1BA-6330-STD	standard			125.00 set
1BA-6330-010	10 undersize			125.00 set
1BA-6330-020	20 undersize			125.00 set
1BA-6330-030	30 unsweaize			125.00 set
Crankshaft Bolt				
This is the bolt that holds the crank pulley on.				
C3AZ-6379	1948-64			1.00 ea.
Flywheel Ring Gear				
8BA-6384	1948-53	239/255 v-8		40.00 ea.
Flywheel to Crank Dowel				
0BA-6397	1950-53			1.50 ea.
Flywheel Housing Cover Seal (rubber)				
8BA-6411	1949-53	239 v-8		12.50 ea.
Valve Lifters				
•ADJUSTABLE LIFTERS				
91A-6500-AD	1932-53	Ford/Mercury		275.00 set.
91A-6500-WRN		wrenches for the above lifter		10.00 pr.
•SOLID LIFTERS				
EAB-6500	1948-53	Ford/Mercury v-8		5.00 ea.
Valves				
8BA-6505	1948-50	239-255 intake & exhaust uses two piece keeper set.		9.00 ea.
1BA-6505	1951-53	intake & exhaust uses the three piece keeper set.		11.50 ea.
Valve Guides				
8BA-6510	1948-53	Ford/Mercury v-8		6.00 ea.
Valve Guide Rubber "O" Rings				
These are used on the intakes to keep oil from getting through the guide.				
8BA-6571	1948-53	Ford/Mercury		.80 ea.

Most orders shipped same day!

We accept



Valve Guide Retainer

40-6512 This is the horse shoe keeper 1948-53 239 v-8 1.50 ea.

Valve Springs

78-6513 239 v-8 use with 8BA-6505 valve 3.00 ea.
 1BA-6513 239 v-8 use with 1BA-6505 valve 3.50 ea.

Valve Spring Retainers

These are used with 8BA-6505 valves.
 8BA-6514 1948-50 steel cup 2.50 ea.

Valve Lock Keys

These are the little two halves that lock the spring keeper to the valve.
 7HA-6518-SPR 6 & 8 cyl. 1948-64 sold in pairs 1.00 pr.

Intake Manifold Gasket

8BA-6521 239 v-8 1948-53 12.00 ea.

New Oil Pump

Does not include pickup tube or screen.
 8BA-6621 1948-53 v-8 155.00 ea.

Oil Pump Screen

68-6623 1936-59 v-8 25.00 ea.

Oil Pump Screen Retaining Clip

8BA-6628 1949-53 all 3.00 ea.

Upper Oil Pump Drive Gear

18-6652 1932-53 239 v-8 7.00 ea.

Idler Gear (oil pump drive in block)

18-6655 1932-53 v-8 20.00 ea.

1949-53 V-8 Engine Specifications

Bore 3.187"

Stroke 3.75 "

Firing Order 1-5-4-8-6-3-7-2

Oil Capacity 4 qts.

Crank Pin Dia. 2.138-2.1390"

Main Journal 2.498-2.4990"

Spark Plug Gap .029-.032

Torque Limits (FT./LBS.)

Main bearings 95-105

Cylinder head nuts 50-55

Cylinder head bolts 65-70

Intake manifold 23-28

Connecting rods 45-50

Spark plugs 24-30

Pressure plate 17-20

Bushing

18-6657 for the above gear 6655 4.00 ea.

Oil Pressure Sending Unit (replacement type)

41A-9278 Ford flathead V8 80# 1942-53 40.00 ea.

Oil Filter Element U.S. MADE GOOD QUALITY			
7HA-6731	1940-53	all	10.00 ea.
Oil Pan Gasket			
8BA-6781	1948-53	v-8	17.50 ea.
Oil Pan Drain Plug and Gasket			
8HA-6730		1948-53 7/8-16 plug	4.00 ea.
8HA-6734		gasket	1.00 ea.
Oil Pan Dipstick			
8BA-6750	1949-53	v-8	8.00 ea.
Oil Breather Cap			
8BA-6766	1949-53	v-8	15.00 ea.

FLAT HEAD SPEED EQUIPMENT

Finned Aluminum High Compression Cylinder Heads (Offenhauser)
 HR-1069 1949-53 Ford and Mercury engines 600.00 pr.

Chrome Acorn Head Nut and Intake Nut Covers

IN-6520-C intake nut covers 9/16" bolt head 15.00 set/20
 CN-6067-C head nut covers 11/16" bolt head 27.50 set/50

Fenton Cast Iron Headers

This is the first step for improved performance. These are the traditional favorite for sweet sound, less under hood noise and longevity.

HR-7101 headers for 1933-53 v-8 300.00 pr.

Header Pipes for 1949-51 Passenger Car

These pipes are needed to connect the headers to the mufflers

HR-5245 fenton header pipes 110.00 pr.

Beehive Oil Filter

These filters are beautiful finned aluminum with a painted body and polished lid. Cools while it filters the oil.

HR-6731-BH firewall mounted for all flatheads 230.00 ea.

Beehive Filter Mounting Bracket

HR-6731-BKP painted bracket 12.00 ea.
 HR-6731-BKC chromed bracket 20.00 ea.

Intake Manifolds (Offenhauser)

HR-1075 1949-53 dual intake 250.00 ea.
 HR-1077 1949-53 triple carb. 350.00 ea.
 HR-1078 1949-53 four barrel carb. 275.00 ea.

Holley Carburetor Mounting Plate for Four Barrel

Note: Certain Holley carburetors may be too wide for the 1937-48 engines due to interference with radiator hose outlets.

HR-9750-P mount plate for four barrel intakes 40.00 ea.

Most orders shipped same day!

We accept



Carburetor Linkage Assemblies

Passenger side ball to ball for dual carburetors (no triples).

HR-1004	standard dual rod is 3.5" long	30.00 ea.
HR-1005	dual carb. rod is 7" long	30.00 ea.
HR-1006	dual carb. rod is 9" long	35.00 ea.
HR-1003	single ended rod for accelerator	25.00 ea.

Drivers side linkage (carburetors must have extended throttle shafts on the left side of the carburetor).

HR-2864	standard dual close carbs.	40.00 set
HR-2865	super dual wide spread carbs.	40.00 set
HR-6271	triple/progressive linkage	85.00 set
HR-2866	triple/unison linkage	55.00 set

Small Diameter Air Cleaners for the Dual and Triple Carb. Set Up

These air cleaners have paper filter element, chrome plated and come either louvered or plain. Fits all Stromburg and Ford carburetors with a 2 5/8" opening.

HR-9600-P	plain sides chrome	12.50 ea.
HR-9600-L	louvered sides chrome	12.50 ea.
HR-9600-F	replacement filter element	4.50 ea.

Carburetor Air Scoops

These scoops are polished aluminum. Scoops fit carburetors with a 2 5/8" opening. They are known as velocity stacks.

SC-9600-PA	scoop	24.00 ea.
------------	-------	-----------

Replacement Parts

HR-29217	chrome mallory coil	26.00 ea.
HR-29216	electronic coil 12 volt only	36.00 ea.
HR-25042	points for dual point dist. 2(req.)	8.00 ea.
HR-209	distributor cap	10.50 ea.
HR-309	rotor	4.00 ea.
HR-10400	condenser	6.50 ea.

Oil Pump (new short body 80#)

Less pickup tube.

8BA-6621		155.00 ea.
----------	--	------------

Iskenderian/Flathead Camshafts

These performance cams are available in various grinds. Use the chart below for more information.

HR-217700	77B cam only for 1932-48	325.00 ea.
HR-817700	77B cam only for 1949-53	325.00 ea.
HR-811100	max 1 for 1949-53	325.00 ea.
HR-211100	max 1 for 1932-48	325.00 ea.
HR-218800	88 gr. for 1932-48	325.00 ea.
HR-818800	88 gr. for 1949-53	325.00 ea.
HR-214000	400 jr. for 1932-48	325.00 ea.
HR-814000	400 jr. for 1949-53	325.00 ea.

Grind	Type	Int.	Exh.	Lift
77B	3/4	20/60	60/20	.325
Max-1	3/4	15/52	57/12	.364
#88	Full Rc.	24/60	64/20	.320
400 Jr.	Track	18/60	60/18	.400

Adjustable Lifters

91A-6500-AD	1932-53 all v-8	275.00 set.
91A-6500-WRN	wrenches for the above	10.00 pr.

Engine Accessories (for use with dual and triple intakes)

All items are aluminum.

HR-3494	oil filter mount spacer (to get above the fins)	18.50 ea.
HR-1081	Offy. polished aluminum fuel block	45.00 ea.
HR-3497	Offy. curved water tube for offset generator clearance on 1949-53 engines	30.00 ea.
HR-1097	finned aluminum carb. block off plate	25.00 ea.
1BA-8592-PA	polished aluminum gooseneck 1949-53	13.00 ea.
HR-3496	Offy. offset gooseneck for generator clearance 1949-53 one per engine	50.00 ea.

Alternator Brackets

HR-916-67908	1932-42 plain aluminum	45.00 ea.
HR-916-67907	1932-42 chrome	70.00 ea.
HR-916-67910	1946-53 plain aluminum	60.00 ea.
HR-916-67909	1946-53 chrome plated	80.00 ea.

Generator and Fan Brackets

The following brackets are for the super dual and triple intakes:

HR-1095	generator bracket (49-53) R.H. side	55.00 ea.
HR-1096	generator bracket (49-53) L.H. side	55.00 ea.
HR-1094	generator bracket (38-48) R.H. side	50.00 ea.
HR-1093	generator bracket (38-48) L.H. side	50.00 ea.
HR-3499	fan carrier bracket 38-53	50.00 ea.

Most orders shipped same day!

We accept



Stainless Steel Generator Covers

Generator covers are for the two brush type generators.

HR-SSGC	1949-53 two piece generator cover	35.00 ea.
HR-GENCOV	1938-41 1 hole generator cover	20.00 ea.
HR-GENCOV2H	1941-48 2 hole generator cover	28.00 ea.

AUTOMATIC TRANSMISSION**Automatic Transmission Overhaul Kit**

Gaskets, sealing rings, and discs.

1P-7A-001	1951-53	239 v-8 & 6cyl.	90.00 kit
-----------	---------	-----------------	-----------

Extension Housing Bushing

B3TZ-7A034-A	1949-66		9.00 ea.
--------------	---------	--	----------

Shifter Parts Automatic Transmission

1M-7246-A	1951-60 shift lever rubber insulator		5.50 ea
-----------	--------------------------------------	--	---------

STANDARD TRANSMISSION**Shift Tower and Linkage Parts**

01A-7246	1940-59 shift lever rubber insulator standard shift		8.00 ea
01A-7354-RK	40-51 shift linkage grommet repair kit (1 kit per car)		30.00 kit
01A-7221	40-53 shift lever retaining pin (2 per car)		6.00 ea

Main Drive Gear (input)

8A-7017	16 teeth	1949-50	80.00 ea.
1A-7017	16 teeth	1951-54	100.00 ea.

Ball Bearings

51A-7025	1940-55	front bearing	40.00 ea.
51A-7065	1940-55	rear bearing	40.00 ea.
8A-7025	1949-59	front bearing	33.00 ea.

Extension Housing Bushing

B3TZ-7A034-A	1949-66		9.00 ea.
--------------	---------	--	----------

Rear Grease Seal

21C-7052	1948-63		6.00 ea.
----------	---------	--	----------

Mainshaft

8A-7061-A	1949-50		85.00 ea.
8A-7061-B	1949-50	with overdrive	55.00 ea.
8M-7061	1949-50	Mercury	70.00 ea.
1A-7061-A	1951		85.00 ea.
B5A-7061-C	1952-56		80.00 ea.

Low & Reverse Slider Gear

01A-7100	1939-50	29 teeth	110.00 ea.
1A-7100	1951-54	28 teeth	140.00 ea.

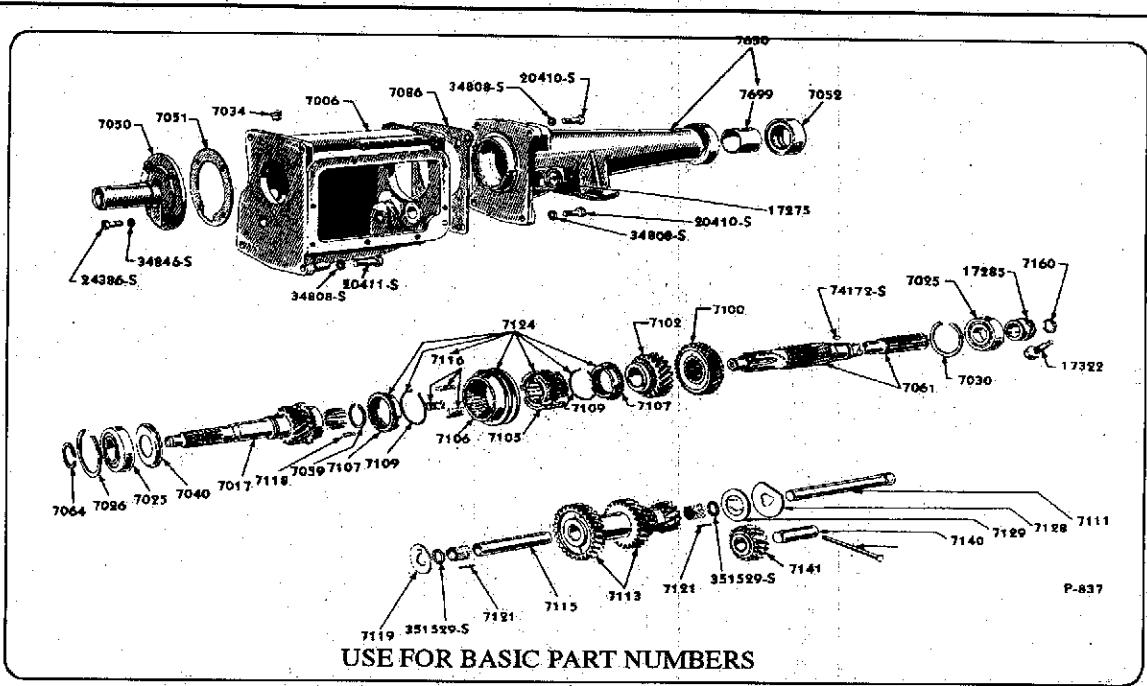

Second Gear

81A-7102	1940-50	use w/8A cluster gear	147.00 ea.
1A-7102	1950-54	use with B4A cluster gear	90.00 ea.

Countershaft

B-7111	1949-50	use w/8A cluster gear	9.00 ea.
8A-7111	1951-54	use with B4A cluster gear	9.00 ea.

Cluster Gears

Use with loose roller bearings.

8A-7113	28-24-18-14 teeth	1949-50	350.00 ea.
B4A-7113	27-23-17-13 teeth	1950-54	350.00 ea.

Needle Roller Bearings (for cluster gears)

Included in small parts kits.

8A-7118-S	1949-59	pack of 15	07.50 pack
8A-7121-S	1949-59	pack of 50	13.00 pack

Complete Synchronizer Assembly

Includes brass rings.

8M-7124	1940-56	125.00 ea.
---------	---------	------------

Synchronizer Clip & Spring Set

51A-7109-S	1940-62	11.50 set
------------	---------	-----------

Synchronizer Brass Blocker Rings

81A-7107	1940-62	7.50 ea.
----------	---------	----------

Cluster Washers

B-7119	front washer	1949-54	5.00 ea.
8M-7128	rear flat washer	1949-54	2.50 ea.
8M-7129	rear thick washer	1949-54	9.00 ea.

Most orders shipped same day!

We accept



Reverse Idler Gear Shaft

B-7140	1949-53 standard transmission		17.50 ea.
--------	-------------------------------	--	-----------

Reverse Idler Gears

68-7141	1940-50	18 teeth	75.00 ea.
1A-7141	1951-54	17 teeth	65.00 ea.

Transmission Gasket Sets

8A-7153-A	1949-50	without overdrive	6.00 set
1A-7153-A	1951	without overdrive	6.00 set
B8AZ-7153-A	1952-59	without overdrive	7.00 set
8A-7153-B	1949-50	with overdrive	9.00 set
B2A-7153-B	1951-53	with overdrive	12.00 set
B6A-7153-B	1956-60	with overdrive	14.00 set

Side cover seals

01A-7288	1949-50 Ford, 49-51 Merc		7.00 ea.
----------	--------------------------	--	----------

Small Parts Kits

Includes: washers, snap rings, needle bearings.
These kits don't fit overdrive transmissions.

8A-7199	1949-50		30.00 kit
B5A-7199	1951-59		30.00 kit

Overdrive Kick Down Switch

8A-6918-B	1949-53		25.00 ea.
-----------	---------	--	-----------

Overdrive Cable

A9AZ-7A650-A	overdrive cable with chrome knob cut length to fit 49-53		50.00 ea.
--------------	--	--	-----------

Overdrive Cable Clip This clip mounts to the steering box to guide the cable.

8A-7713	1949-52 car, 1952-53 with auto trans holds speedo cable		5.00 ea.
---------	---	--	----------

Knob for overdrive and hood release cable Includes set screw

A9AZ-7A650-K	Knob for overdrive cable 1949-64 Ford full size		20.00 ea.
8A-16916-K	Knob for hood release cable 1949-51 Ford car		20.00 ea.

Clutch Release Fork

A9A-7515	1949-51		20.00 ea.
----------	---------	--	-----------

Clutch Pedal Spring

8A-7523	1949-50		4.00 ea.
1A-7523-B	1951		10.00 ea.
AB-7523-B	1952-54		4.00 ea.

Clutch Pedal Bushing (shaft housing) refer to illustration

01A-7526	1949-51	2 required	3.00 ea.
----------	---------	------------	----------

Clutch Discs

There is no core charge. These discs are brand new U.S.A. made.

8BA-7550	9-1/2" 10 spline		75.00 ea.
B5A-7550	10" 10 spline		60.00 ea.

Throwout Bearing Only

8A-7580	1949-64 bearing only		20.00 ea.
---------	----------------------	--	-----------

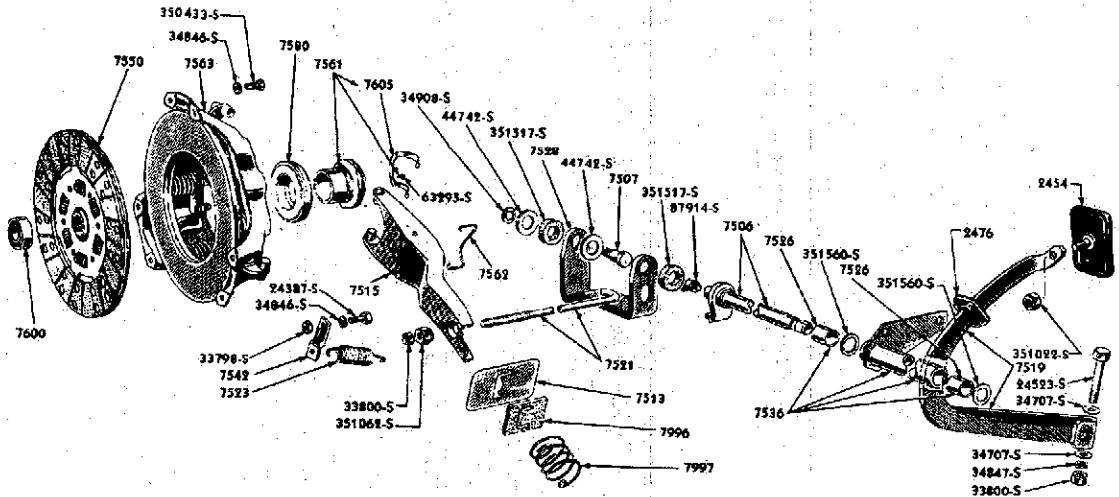

USE FOR BASIC PART NUMBERS

Pilot Bearings

B-7600	double shielded roller bearings	1949-53	6.00 ea.
70-7600	bronze bushing	1949-53	6.00 ea.

Pressure Plates

There is a \$30.00 core charge if your old plate is not sent. These plates have all new springs and are completely rebuilt and adjusted.

1A-7563	9-1/2"	1949-54	135.00 ea.
19A-7563	10"	1949-54	125.00 ea.

Clutch Pedal Rubber Bumper

MA-7583	1952-64		2.00 ea.
---------	---------	--	----------

Clutch Rod and Rubber Boot

8A-7521-BR	1949-early 50 clutch rod 11 1/4"		15.00 ea.
BA-7527	1952-53 seals clutch rod to the floor		15.00 ea.

COOLING SYSTEM

Temperature Sender

8A-10990	2-prong 6-volt	1949-53	70.00 ea.
8A-10884	single screw	1949-53	65.00 ea.

Radiator Caps

26H-8100-R	1949-53	replacement cap	15.00 ea.
------------	---------	-----------------	-----------

Radiator Drain Cock

8A-8115	1949-53 NOS	1/4" pipe thread	6.00 ea.
---------	-------------	------------------	----------

Water Outlet Gasket

This is the gasket for the thermostat housing.			
8BA-8255	1948-53 v-8 Ford & Merc.		1.25 ea.

Most orders shipped same day!

We accept



Radiator Hoses

1BA-8260	1949-53	upper hose v-8	15.00 ea.
8BA-8286	1949-53	lower hose v-8	9.00 ea.

Radiator Hose Kit

Includes all four hoses and all the clamps. Ford script
 1BA-8285-S 1949-53 v-8 70.00 kit.

Hose Clamps

8BA-8287	upper hose clamp	1.50 ea.
A-8287	lower hose clamps	1.50 ea.

Water Pump to Block Gasket

8BA-8507	1949-53 Ford & Merc. v-8	3.00 ea.
----------	--------------------------	----------

Radiator Supports to Frame Pads

8A-8125	1949-53	4.00 ea.
---------	---------	----------

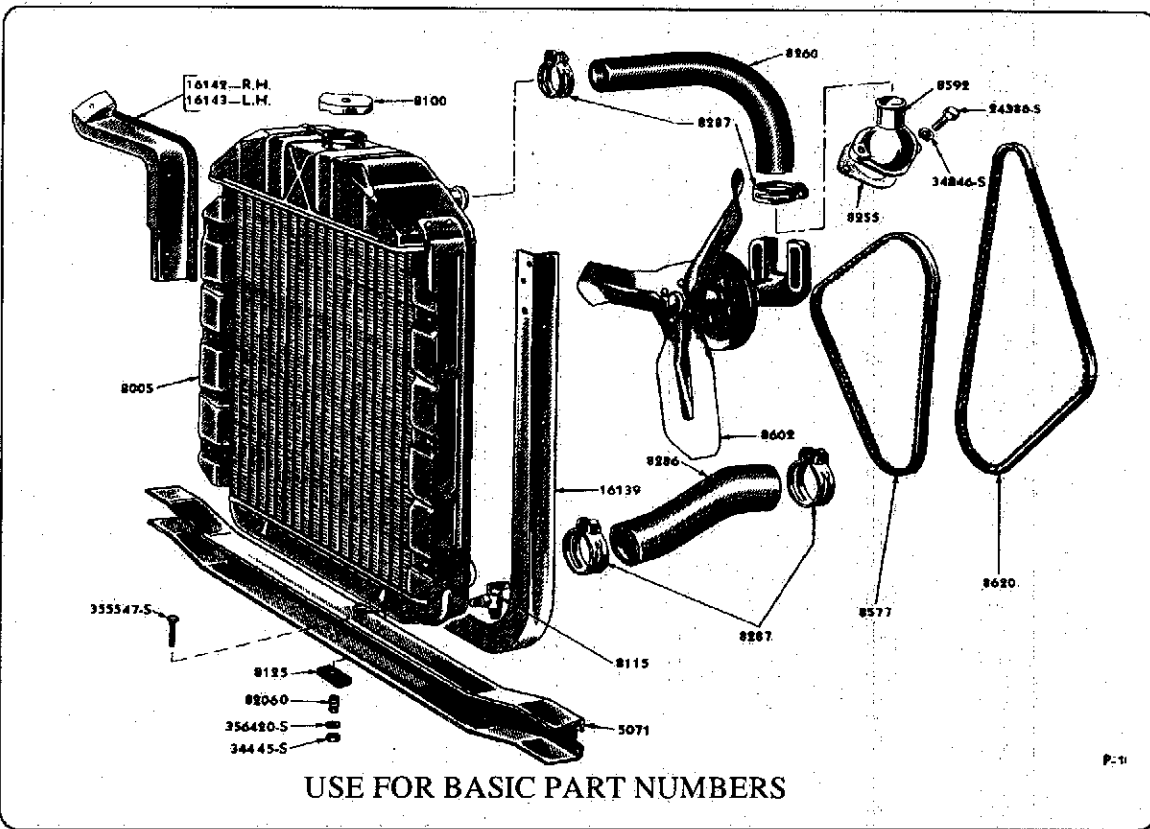

Radiator Air Deflector Seals

1BA-8344	1949-51	deflector to hood seal	15.00 ea.
8BA-8349	1949-53	deflector to top radiator seal	4.00 ea.
BA-8344	1952-54	deflector to hood seal	9.00 ea.

Thermostats

These are for 1949-53 v-8 engines, two required per engine.
 1BA-8575-A 160 degrees Ford & Merc 10.00 ea.

Water Pumps (new) *Note these pumps will not fit Mercury.

8BA-8501-N	1950-53 narrow belt RH (passenger side)	90.00 ea.
8BA-8502-N	1950-53 narrow belt LH (driver side)	90.00 ea.
8A-8501-N	1949 Wide Belt RH (passenger side)	90.00 ea.
8A-8502-N	1949 Wide Belt LH (driver side)	90.00 ea.

Pulley

8BA-8509	RH Narrow belt	15.00 ea.
BOAZ-8509	LH Narrow belt	20.00 ea.
8RT-8509-A	Wide belt 1949 LH or RH	20.00 ea.

Water Pump Rebuild Kit

Each kit includes all the parts of the water pump except the housing and pulley.

A8C-8591	1950-53 V-8 Ford & Merc.	30.00 ea.
----------	--------------------------	-----------

Water Outlet Housing

This is the thermostat housing. Ford & Merc.

1BA-8592	1949-53 v-8	16.50 ea.
1BA-8592-PA	polished aluminium	13.00 ea.

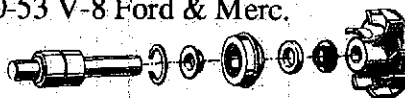
**Fan Belts/Generator/Water Pump Ford & Mercury**

	1949 239 V-8 WIDE BELT	
21A-8577	fan belt	30.00 ea.
78-8620	generator belt	21.00 ea.
7RA-8620-C	1949 water belt and generator belt with Ford Script	25.00ea.
	1950-53 THIN BELT 239 V-8	
8BA-8577	fan	11.00 ea.
8BA-8620	generator	12.00 ea.

FUEL SYSTEM PARTS**Gas Cap**

C7AZ-9030-A	1950-70 regular cap	8.50 ea.
01A-18416-A	accessory locking cap	35.00 ea.
8A-9030	1949-52 Ford & Merc. Stainless	10.00 ea.

Gas Filler Neck Hose Clamps

11A-8287	1949-51	2 required	1.50 ea.
----------	---------	------------	----------

Gas Filler Neck Connecting Hose

11A-9047-A	Ford & Merc.	1941-51	7.50 ea.
------------	--------------	---------	----------

Filler Pipe to Trunk Floor Seal

1A-9072	1949-51	5.00 ea.
---------	---------	----------

Gas Tank to Body Pads

8A-9052	1949-51	18.00 kit
---------	---------	-----------

Filler Pipe to Quarter Panel Gasket

8A-9076	1949	3.00 ea.
---------	------	----------

Most orders shipped same day!

We accept



Filler Pipe Neck to Quarter Panel Grommet

8A-9080	1949	25.00 ea.
0A-9080	1950-51 & Merc.	8.00 ea.
0A-9084	1949-51 wagon	20.00 ea.
BA-9080-A	1952-56	7.50 ea.

Gas Filler Door Spring

0A-16377	1950-51 cars except wagon	12.00 ea.
----------	---------------------------	-----------

Gas Tank Filler Door Bumpers

0A-16378	1950-51	3.00 pr.
BA-13398-B	1952-55	5.00 pr.
1M-7228626	1951 Merc.	2.00 ea.

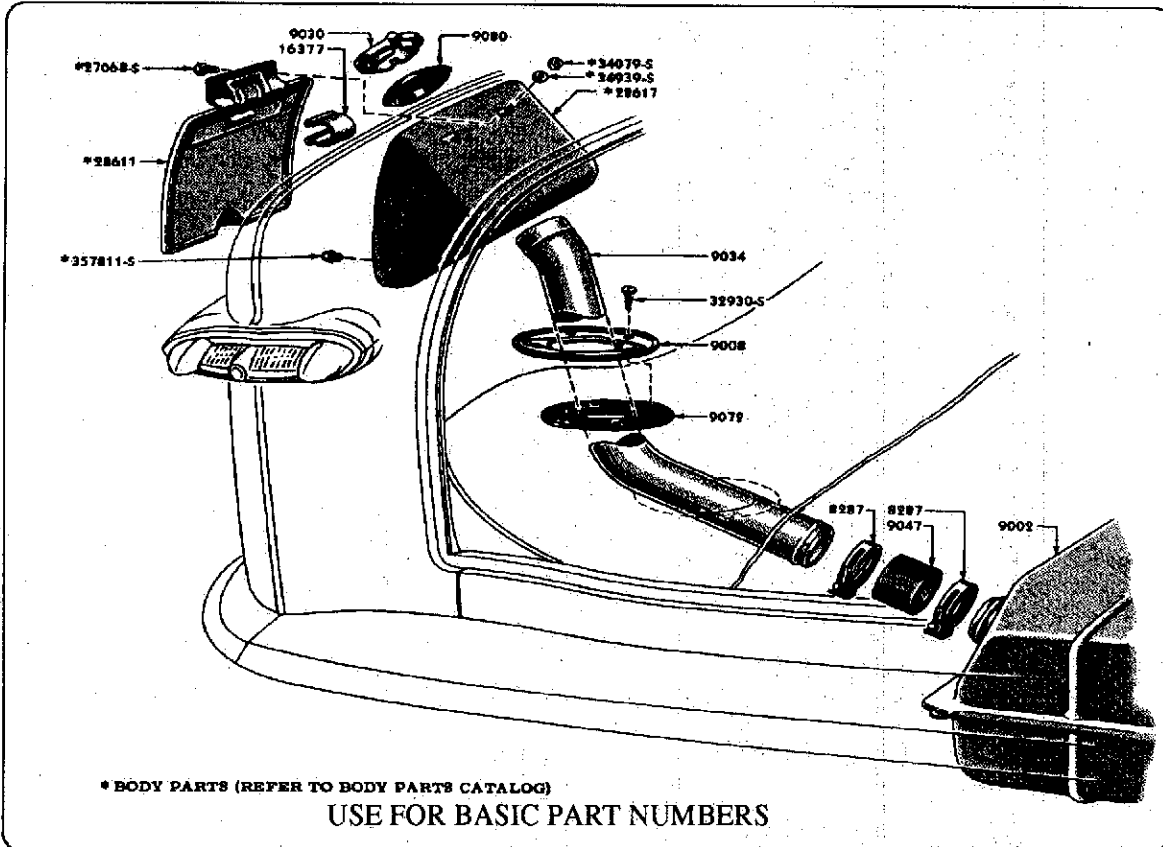

Oil Pressure Sending Unit (replacement type)

41A-9278-R	6-volt 80#	1949-53	16.00 ea.
------------	------------	---------	-----------

Flexible Fuel Lines

This is the line from the fuel pump to the main steel line to the tank.

7HC-9288	1949-50	8.50 ea.
1A-9288	1951-58	9.50 ea.

Steel Fuel Line

818-9282	1949-51	12' x 1/4" gas tank to cowl, uses your old fittings, copper plated	18.00 ea.
----------	---------	--	-----------

Fuel Pump Diaphragm

This is the diaphragm and sediment bowl gasket, no valves.

68-9398-A 1949-53 12.00 ea.

Fuel Pumps

7RA-9350 1949-50 single action, with standard transmission 70.00 ea.

1BA-9350 1951-53 single action, standard transmission 70.00 ea.

7HA-9350 1949-50 6 cyl. 72.50 ea.

Fuel Pump Push Rod

EAB-9400 1949-53 v-8 15.00 ea.

Fuel Pump Stand

8BA-9416 1949-53 v-8 20.00 ea.

**Fuel Pump Gasket**

7RA-9417 1948-53 v-8 1.00 ea.

40-9374 1949-53 1.00 ea.

Exhaust Manifold Gaskets

This is a set of eight. Ford & Merc.

18-9433 1948-53 v-8 8.00 set

Gas Tank Sealer

Stops rust, leaks and corrosion permanently. Resistant to all fuels, including the new phase II oxygenated fuels. Heavily compounded with rust inhibitors. Permanently bonds to all metal or fiberglass tanks. The only sealer on the market approved for use in aircraft.

GTS-05 sealer 27.00 quart

Gas Tank Etch

Will remove light build-up of rust inside of all tanks and will etch the inside of the tank leaving a gray phosphate coating. An excellent preparation for your tank before sealer with the above tank sealer.

TE-01 gas tank etch 12.00 16 oz.

Gas Preservative and Stabilizer

Prevents gum, varnish formation, and corrosion in fuel tanks and fuel systems. One ounce of this product will keep three gallons of fuel fresh for at least three years. Contains no alcohol that attacks some metals. One quart will protect 100 gallons of fuel for three years.

FPS-01 fuel preservative 17.00 quart

Gas Tank Sending Unit and Parts Ford & Merc.

99A-9275 1949-53 gas tank sending unit (replacement) 50.00 ea.

68-9276 sending unit to tank gasket 3.00 ea.

68-9275-F sending unit float (brass) 11.00 ea.

Crossover Pipe Gasket

C1SZ-9450 1949-62 v-8 2.50 ea.

Carburetor Rebuild Kit

Kit includes: gaskets, needle and seat, power valve, accelerator pump.

59A-9590 1940-53 ford/holley carb. 25.00 ea.

7HA-9590-A 1949-51 6 cyl. 18.00 ea.

B2A-9590-A 1952-57 6 cyl. 37.00 ea.

EAC-9590 Mercury 62.50 ea.

Most orders shipped same day!

We accept



Carburetor Gasket set

21A-9502 1938-53 v-8 5.50 kit

Carburetor Small Parts

78-9550 1938-53 float Ford carb 15.00 ea.
 78-9564 Ford needle & seat 3.00 ea.
 78-9516 base to body gasket Ford carb .75 ea.
 78-9563 bowl plug gasket Ford carb .10 ea.
 78-9564 accelerator pump needle valve Ford carb 3.00 ea.
 78-9904 power valve Ford carb 1938-53 2.50 ea.

Fuel Line To Frame Clip

51C-14197 for fuel and brake lines exactly as original 3.00 ea

Accelerator Pedals

8A-9735 1949-50 all 15.00 ea.
 1A-9735 1951 all 15.00 ea.
 B4A-9735 1952-54 all 12.00 ea.

Accelerator Pedal Rod Seal

8A-7012177-S 1949-51 passenger cars 3.00 ea.
 BA-9738-S 1952-53 rod seal cars 2.00 ea.

1949-51 Accessory Gas Pedal Cover

8A-9738-S pedal cover 16.50 ea.

Choke Cable and Choke Knobs

0A-9700-B 1950 ivory knob only 5.50 ea.
 0A-9700-C 1950 black knob only 6.00 ea.
 0BA-9700-B 1950 cable with ivory knob 20.00 ea.
 0BA-9700-C 1950 cable with black knob 20.00 ea.
 8A-9700-C 1949-51 choke cable, no knob 14.00 ea.
 B-14607 1949-51 choke cable grommet 1.00 ea.

GENERATOR PARTS

Armature/ Ford & Merc.

01A-10005 1940-53 30 amp 80.00 ea.

Generator Small Parts/ Ford & Merc

01A-10043 1949-53 brushes all 4.00 set
 91A-10057 1940-59 brush spring 2.00 ea.
 78-10120 1940-56 through bolt 2.00 ea.
 78-10128 1940-53 rear bushing 1.25 ea.
 B-7600 1940-53 front roller bearing 6.00 ea.
 81A-10175 1940-56 field coils 6 volt 60.00 set
 B6A-10175-B 1940-56 field coils 12 volt 60.00 set

Generator Metal I.D. Tags

CC-101 1949-53 6.50 ea.

Voltage Regulator

51A-10505 1940-55 6 volt 35 amp 55.00 ea.
 B6A-10505 1940-55 12 volt 50.00 ea.

Voltage Regulator I.D. Metal Tag

CC-104	1949-53	tag	6.50 ea.
--------	---------	-----	----------

Rebuilt Generator/ Ford & Merc.

These units are remanufactured with all new parts. Not just repaired. Core charge 60.00.

8BA-10000-R	1949-53 6 volt	225.00 exchange
8BA-10000-12	1949-53 12 volt	225.00 exchange

WE REBUILD GENERATORS AND STARTERS!**STARTER SECTION****Rebuilt Starter (starter drive not included)**

This is a remanufactured starter using high torque field coils for a much stronger start. Almost all parts are replaced with new. Ford & Merc. Core charge is 60.00.

18-11002	1932-53 standard transmission	225.00 exchange
18-11002-12	same as above 12 volt	225.00 exchange

Starter Armature

18-11005	1932-53 std. transmission Ford & Merc.	70.00 ea.
----------	--	-----------

Starter Small Parts\ Ford & Merc

B-11052	front bushing	1940-59	1.25 ea.
18-11057	brushes 4pcs.	1940-59	5.00 set
18-11083-S	field coil set	1940-53	35.00 set

Terminal Post Kit Ford & Merc.

Kit includes terminal post, insulators and hardware.

18-11102-O	1932-53 oval hole in housing	10.00 kit
18-11102-R	1932-53 round hole in housing	10.00 kit

End Plate Bushings Ford & Merc.

B-11135	1940-53	for drive end plate	1.50 ea.
---------	---------	---------------------	----------

Starter Metal I.D. Tag

CC-103	1949-53	tag	6.50 ea.
--------	---------	-----	----------

Starter Bendix Ford & Merc.

B-11350	1940-53	standard transmission	35.00 ea.
ICM-11350	1951-60	with auto transmission	45.00 ea.

Bendix Drive Springs Ford & Merc.

B-11375	use with B-11350	7.50 ea.
ICM-11375	use with ICM-11350	7.00 ea.

Starter Solenoid

21A-11450	1940-50 plastic case	push button	20.00 ea.
21A-11450-M	1949-50 metal case,	Fomoco stamped	25.00 ea.
01A-11450	1940-50 metal case	Ford stamped	25.00 ea.
1A-11450	1951 plastic case	no push button	20.00 ea.
B5A-11450	1952-55		20.00 ea.

Most orders shipped same day!

We accept



Starter Button on Dash

6A-11500 1940-50 chrome 8.00 ea.

IGNITION PARTS

Ignition Switch

B5A-11572 1952-59 does not include lock cylinder and key 25.00 ea.

Ignition Switch Bezel

Life time shine! Stamped from staninless steel.

0L-11580 1950-51 Merc/Lincoln 15.00 ea.

0A-11580 1947-50 Ford, 1949 Merc 15.00 ea.

Lock Cylinder and Key for Above Switch

B9A-11582 1952-59 10.00 ea.

Door Locks and Ignition Switch Cylinder with Matched Keys

BAAA-7022050-S 1952-58 (except retract. & wagon) 55-60 Thunderbird 50.00 set

8A-7022050-S 1949-51 Ford & Mercury with 1949-50 style keys 60.00 set

6-Volt Coil (internal resistor)

8BA-12029 1949-59 Ford & Merc. coil 25.00 ea.

Distributor Caps

7HA-12106 1949-70 6 cylinder 12.00 ea.

FAB-12106 1949-56 Ford & Merc. 8 cylinder 13.00 ea.

Distributor Bushings

These parts are for the cast iron 7RA distributor.

7RA-12120 1949-56 upper bushing 2.00 ea.

7RA-12132 1948-53 lower bushing 2.00 ea.

Rotor Ford & Merc.

FAA-12200 1948-56 v-8, 48-70 6 cylinder. 3.00 ea.

Points

8BA-12199 Old stock points USA made 1948-53 5.00 set

Rotor to Shaft Clip

0BA-12213 1949-64 all 6.50 ea.

Distributor Internal Wires

7RA-12264 1948-56 breaker gnd. wir 1.25 ea.

7RA-12216 1948-56 primary wire .90 ea.

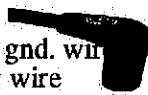

Spark Plug Wires Ford & Merc.

8BA-12259 1949-53 v-8 43.00 set

1A-12259 1949-53 wires with Ford script molded rubber boots over plugs 90.00 set

1A-12259-W same as above without Ford script 56.00 set

Condenser

7RA-12300 1949-53 Ford & Merc. 3.00 ea.

Vacuum Advance Diaphragm

7RA-12370 1949-53 Ford & Merc. v-8 30.00 ea.

Spark Plugs Ford & Merc.

81A-12405 1949-53 2.35 ea.

Distributor I.D. Tags This is the metal tag on the side of the distributor.

CC-105 for aluminum housing 0BH-12127 6.00 ea.

CC-106 for iron housing 7RA-12127-C 6.00 ea.

HEADLIGHTS**6-Volt Sealed Beam Bulb Ford & Merc.**

B5AF-13007 1940-56 12.00 ea.

01A-13007-FS-6 1940-56 Ford script, halogen 6 volt 65.00 ea.

Headlight Buckets (with inner nest for bulb).

1C-13008-A 1949-50 Ford and Mercury LH or RH 75.00 ea.

1A-13008-A 1951 fits LH or RH 75.00 ea.

Bulb Retainer Ring

01A-13018 1940-56 plain steel 15.00 ea.

01A-13018-SS 1940-56 stainless steel 30.00 ea.

Headlight Dimmer Switch

A8AZ-13A024 1948-56 25.00 ea.

C5ZZ-13533 All. Rubber cover 4.00 ea.

Headlight Switch

FAA-11654 1950-54 75.00 ea.

Headlight Bucket Spring

11A-13031 1949-53 2.25 ea.

Headlight Switch Knobs

0A-11661-B 1950 all except Crestliner ivory knob & shaft 9.00 ea.

0A-11661-C 1950 Crestliner black knob & shaft 9.00 ea.

Light Bulbs

B5AF-13007 1949-55 headlight 12.00 ea.

B-13465-1129 1949-51 back up light 1.00 ea.

11A-13465-1154 1949-54 taillight, park light with turn signals 1.25 ea.

78-13466-55 1949-55 radio dial knob 1.50 ea.

B-13466-63 1949-55 dome light, license light, park light, no signals 1.00 ea.

48-15021-51 all cigar lighter, high beam, heater switch bulb 1.50 ea.

78-13466-55 all clock bulb 1.50 ea.

Stop Light Switch

11A-13480 1939-60 all 9.00 ea.

Most orders shipped same day!

We accept



Headlight Door

This is the trim ring around the headlights.

FAD-13045 1949-50 cars 25.00 ea.

Headlight Ring Spring Retainer (Inside)

FAA-13067-A 1952-53 car set of 6 6.00 set

Headlight Bucket to Fender Gasket

11A-13044 1941-56 sold in pairs 8.00 pr.

Headlight Bucket Wires

These are rubber covered.

0A-13076-G 1949-51 Headlamp pigtail with molded grommet 21.00 ea.

B5T-13076-G 1952-54 Headlamp pigtail with molded grommet 22.00 ea.

Headlight Rim Screws

8A-13048-S 1949 1.50 set

0A-13048-S 1950 1.50 set

1A-13048-S 1951 1.50 set

BA-13048-S 1952 1.50 set

DF-13048-S 1953 1.50 set

Headlight Bucket Fastener Kit

This is all the hardware for one bucket.

8A-13050-S 1949 10.00 set

0A-13050-S 1950 10.00 set

1A-13050-S 1951 10.00 set

BA-13050-S 1952 10.00 set

BF-13050-S 1953 10.00 set

PARKING LIGHTS

Parking Lamp Bucket

8A-13215 1949 cars RH 25.00 ea.

8A-13216 1949 cars LH 25.00 ea.

0A-13215 1950 cars RH 25.00 ea.

0A-13216 1950 cars LH 25.00 ea.

Parking Lamp Socket and Wiring 1949-50

0A-13234 49-50 special twist and lock socket 23.00 ea.

Parking Lamp Assembly

This is the bucket, socket, wire, lens, gasket and chrome ring.

1A-13200 1951 cars right or left 35.00 ea.

0A-13200-A 1950 rh no turn signal 75.00 ea.

0A-13201-A 1950 lh no turn signal 75.00 ea.

0A-13200-B 1950 rh with turn signal 75.00 ea.

0A-13201-B 1950 lh with turn signal 75.00 ea.

Parking Lamp Lenses

8A-13208	1949	R.H. glass	8.50 ea.
8A-13209	1949	L.H. glass	8.50 ea.
0A-13208	1950	plastic	5.00 ea.
1A-13208	1951	plastic	5.00 ea.
FAA-13208-B	1952	plastic	16.00 ea.
FAF-13208-A	1953	plastic	6.00 ea.
7RA-13208	1949 Merc.		15.00 ea.
0M-13208	1950 Merc.		10.00 ea.
FAB-13208	1952-53 Merc.		6.00 ea.

Parking Lamp Lens Door

0A-13210	1950 fits right or left		21.50 ea.
1A-13210	1951 left or right		14.00 ea.
FAD-13210-A	1953 RH		28.50 ea.
FAD-13212-A	1953 LH		28.50 ea.

Parking Lamp Lens Gaskets

8A-13211	1949		4.00 pr.
0A-13211	1950		4.00 pr.
1A-13211	1951		6.00 pr.
FAA-13211-A	1952		6.00 pr.
FAF-13211-A	1953		6.00 pr.
7RA-13211	1949 Merc.		5.00 pr.
0M-13211	1950 Merc.		8.00 pr.
1M-13211	1951 Merc.		8.00 pr.
FAB-13211	1952-53 Merc.		6.00 pr.

Parking Lamp Assembly To Fender Pads

8A-13217-B	1949		8.00 pr.
0A-13244	1950		3.50 pr.
1A-13244	1951		6.00 pr.

1949-50 Parking Lamp Rubber Boots

These are the boots on the back of the buckets. These are used without turn signals.

6A-13225	1942-50		17.50 pr.
----------	---------	--	-----------

Turn Signal Flasher Units

These are for 6-volt systems.

A9AZ-13350	3 prong		11.00 ea.
------------	---------	--	-----------

Turn Signal Switch and Cancelling Cam

B5A-13341-A	1951-55 Switch		60.00 ea.
8A-13318	1949-50 Cancelling Cam		17.50 ea.
FAB-13318	1951 Cancelling Cam		17.50 ea.

Turn Signal Knobs

0A-13305-B	1949-51	ivory color	6.00 ea.
0A-13305-C	1949-51	black color	5.50 ea.

Most orders shipped same day!

We accept



LICENSE PLATE LIGHT AND BRACKET

8A-5039-S	1949-51	license bracket to body pads	2.00 pr.
8A-8167-A	1949-51	license plate-trunk bumpers	2.00 ea.
7RA-13568	1949-51	license lens gasket	2.00 ea.
FAA-13568-A	1952-56	license lens gasket	1.25 ea.
1A-13413	1951	light wire through trunk grommet	1.00 ea.
FAA-13560-A	1952-59	light socket and wire	11.00 ea.
8A-13550-A	1949-50	license lamp assy. complete ex. wagon	30.00 ea
1A-13550-A	1951, 1949-51	Mercury complete lamp assy.	30.00 ea
7RA-13564	1949-51	glass license lens	10.00 ea
7RA-13566	1949-51	license lens retainer ex. wagon	15.00 ea
8A-17736	1949-51	front license bracket	15.00 ea.

TAILLIGHTS

1949-51 Taillamps

8A-13404-A	1949-50	all except wagon, complete assy. glass lens	75.00 ea
8A-13404-BD		same as above, with blue dot glass lens	80.00 ea.
1A-13404-A	1951	right side (passenger) complete assy,	100.00 ea
1A-13405-A	1951	left side (drivers) complete assy.	100.00 ea.

Taillight Socket and Wires

FE8H-13410-LS	1949-50	less socket	11.00 ea.
8A-13410-A	1949-50	taillamp socket and wires metal turn and lock type	20.00 ea.
1A-13410	1951-54		5.25 ea.

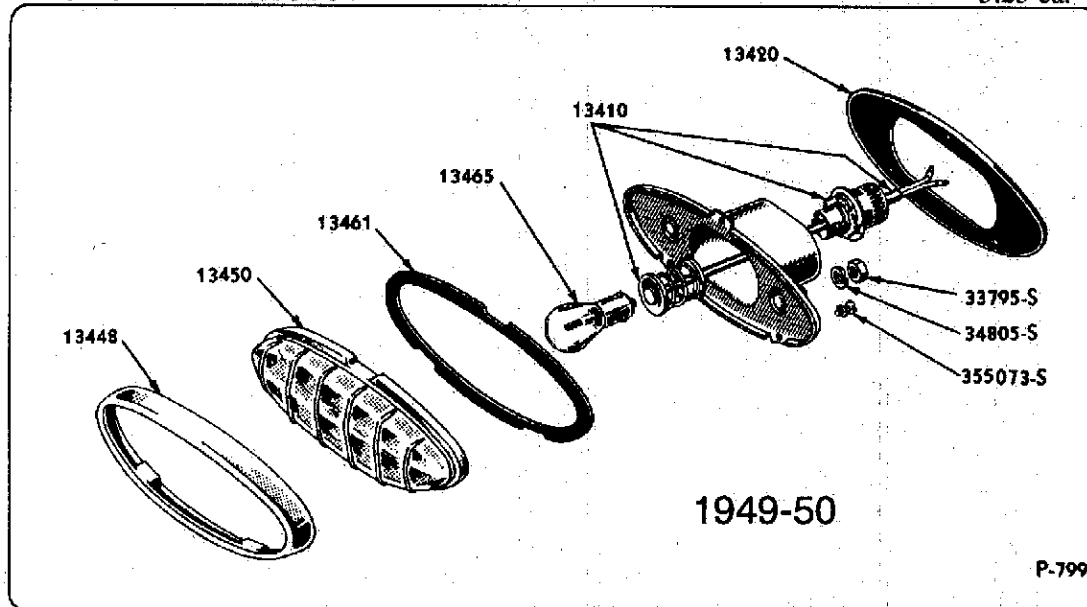

Taillight to Body Pads

8A-13420-A	1949-50		6.00 pr.
1A-13420-B	1951		4.00 pr.
1A-13415	1951	bumpers at back of taillamp housing	4.00 set
FAA-13420	1952-54		10.00 pr.
8M-13420	1949-50	Merc.	20.00 pr.
1M-13420	1951	Merc.	25.00 pr.

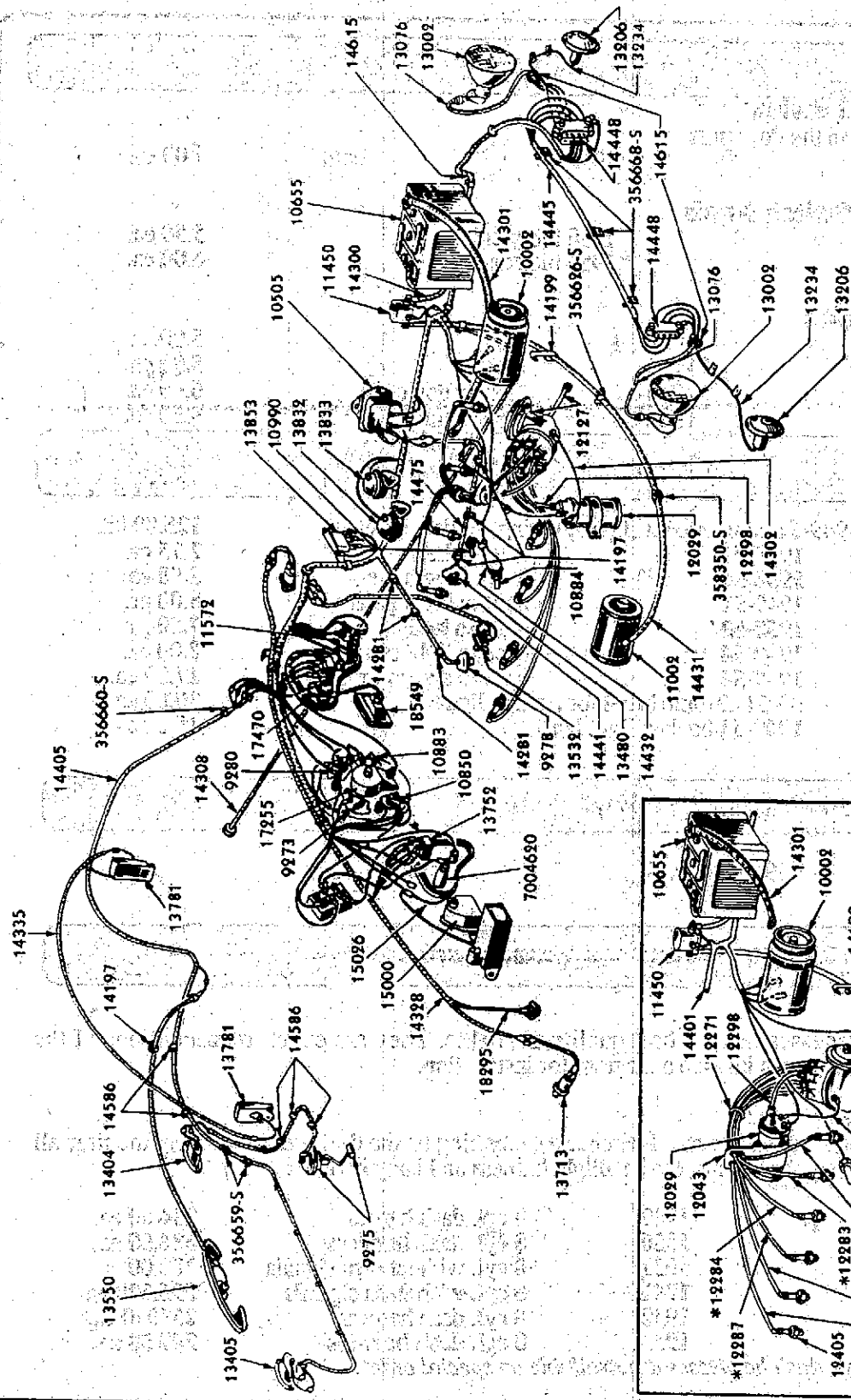

8 CYLINDER WIRING DIAGRAM (6 CYL. SAME EXCEPT AS SHOWN ON INSERT)

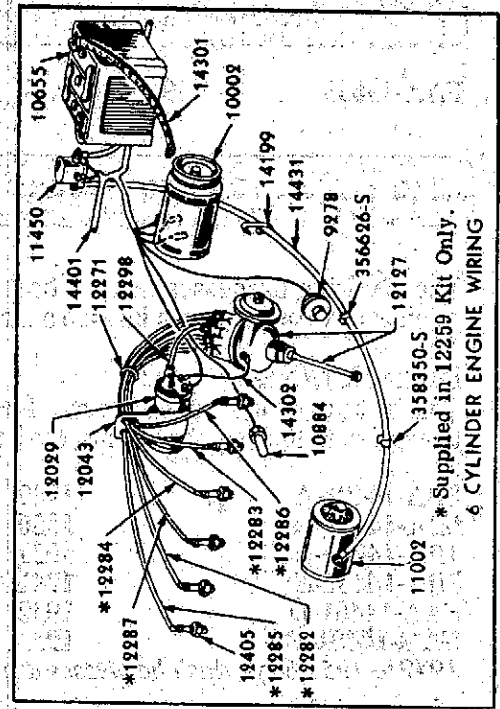

* Supplied in 12259 Kit Only.
6 CYLINDER ENGINE WIRING

1951 Wiring Illustration
use for basic part numbers

Most orders shipped same day!

We accept



Taillight Rim

These are die cast and chrome plated, just like the originals.

8A-13448-A	1949-50		20.00 ea.
1A-13448-A	1951	chrome plated stamped steel	25.00 ea.
FAA-13448-A	1952	lens bezel chrome	41.00 ea.
B3AZ-13434-A	1953	lens bezel chrome	55.00 ea.

Taillight Body

8A-13434	1949-50	stamped steel main body	30.00 ea.
1A-13435-A	1951	left side chrome plated	50.00 ea.
1A-13434-A	1951	right side chrome plated	50.00 ea.

Taillight Lenses

8A-13450	1949-50	glass	10.00 ea.
8A-13450-BD	1949-50	blue dot	15.00 ea.
1A-13450	1951	plastic	13.00 ea.
1A-13437-PR	1951	lens reflector sold in pairs	15.00 pr
FDA-13450	1953		10.00 ea.
FAF-13450	1953	with chrome rim	19.50 ea.

Taillight Lens Gaskets

8A-13461	1949-50		4.00 pr.
1A-13461	1951		5.00 pr.
FAA-13461-C	1952		8.00 pr.
FAE-13461-A	1953-54		4.50 pr.
8M-13461	1949-50	Merc.	7.00 pr.
1M-13461	1951	Merc.	10.00 pr.
40-13460	1933-36		6.00 pr.

1951 Taillight Housing to Body Seal

1A-13453	1951		8.00 pr.
----------	------	--	----------

1951 Taillamp Spears

Chrome plated as original.

1A-29028-9	1951	Ford	250.00 pr.
------------	------	------	------------

DOME LIGHT PARTS

Courtesy Light Switch

This is the switch in the door post.

8M-13713	1949-53	cars	8.00 ea.
----------	---------	------	----------

Interior Light Switch Knob

0A-13755-B	1950	ivory color	5.50 ea.
0A-13755-C	1950	black color	6.00 ea.

Dome Light Lens

8A-13783-A	1949-50	lens	5.00 ea.
1A-13783-C	1951	lens	7.50 ea.
8M-13783	1949-51	lens wagon only	6.00 ea.
FAA-13783-A	1952-53	closed car	7.00 ea.

BACK UP LIGHT PARTS

8A-18275-A	1949-51 complete kit (lights, wiring, switch, bracket)	125.00 kit
8A-15510	1949-51 lens gaskets	5.00 pr.
FAA-15510	1952-54 lens gaskets	5.00 ea.
8A-15533	1949-51 light to body pads	12.00 pr.
FAB-15533-A	1952-53 light to body pads	8.00 pr.
51A-15520-A	1949-54 backup light switch	10.00 ea.
51A-15517-A	1949-54 backup switch bracket	17.00 ea.
8A-15513	1949-51 chrome bezel for backup light	30.00 ea
8A-15514-A	1949-51 backup light lens	15.00 ea

HORN RELAY

FAA-13853	1949-53 6 volt	15.00 ea.
-----------	----------------	-----------

WIRING

These wiring harnesses are the best quality available. They are exact reproductions of the originals. Most harnesses include a diagram for installation.

Dash Harness 1949 to 1953 6 cyl. dash harnesses are available on special order.

This is the main harness of the car. It connects everything on the dash and follows out the firewall to connect to the engine systems, the headlight harness and body harness.

8BA-14401-A	1949	8 cyl. dash harness	266.00 ea.
0BA-14401-A	1950	8 cyl. dash harness	253.00 ea.
1BA-14401-A	1951	8 cyl. without turn signals	325.00 ea.
1BA-14401-E	1951	8 cyl. with turn signals	352.00 ea.
FAA-14401-D	1952	8 cyl. dash harness	300.00 ea.
FAG-14401-H	1953	8 cyl. dash harness	279.00 ea.

Headlight Cross Over Harness

This harness crosses at the radiator to connect the headlights together.

8A-11653	1949	headlight harness	58.00 ea.
0A-14445	1950	headlight crossover	27.00 ea.
1A-14445-A	1951	without turn signals	30.50 ea.
1A-14445-B	1951	with turn signals	36.50 ea.
FAA-14445-B	1952	with turn signals	23.00 ea.
FAA-14445-F	1953	with turn signals	39.00 ea.

Body Harness

This is the harness that runs from the firewall area to the rear area of the car to connect the taillights and other parts.

0A-14405	1949-50	closed cars	71.50 ea.
0BA-14405-B	1949-50	convertible	134.00 ea.
1A-14405-A	1951	all except Victoria	92.00 ea.
1A-14405-D	1951	Victoria	132.00 ea.
1A-14405-B	1951	convertible	151.50 ea.
FAB-14405-S	1952-53	convertible	144.00 ea.
FAB-14405-B	1952-53	4D mainline, custom with turn signals	133.50 ea.
FAB-14405-E	1952-53	Victoria	160.00 ea.
FAB-14405-A	1952-53	tudor with turn signals	162.50 ea.

Most orders shipped same day!

We accept



Headlight Pigtails

This is the short harness that feeds each individual headlight.

All sockets are included to connect to the headlight bulb.

0A-13076-G	1949-51	pigtail with original molded grommet	21.00 ea.
B5T-13076-G	1952-54	pigtail with original molded grommet	22.00 ea.

Taillight Pigtails

This is the individual wires for the taillight itself.

FE8H-13410-LS	1949-50	socket not included	11.00 ea.
8A-13410-A	1949-50	socket and wires metal turn to lock type	20.00 ea.
1A-13410	1951-54	taillight socket and wire	5.25 ea.

Horn Wires

8A-14308	1949-50	horn button wire in column	5.00 ea.
1A-14308b-WP	1951-54	horn wire with spring and shell in column	9.00 ea.
FAA-14440-MU	1952	horn relay to horn wire 43"	12.50 ea.
FAC-14440-B	1952-53	horn relay to horn wire 62"	17.00 ea.

Parking Light Wires

8A-13234-A	1949	park light socket repair kit does not include socket.	4.50 ea.
0A-13234-BR	1949-50	park & turn socket repair kit R.H.	17.00 ea.
0A-13234-BL	1949-50	park & turn socket repair L.H.	17.00 ea.
0A-13234-A	1950	park light repair kit	4.50 ea.
1A-13204-AR	1951	R.H. pigtail with turn signals	21.00 ea.
1A-13204-AL	1951	L.H. pigtail with turn signals	21.00 ea.
FAA-13206-BR	1952	R.H. pigtail with turn signals	24.50 ea.
FAA-13206-BL	1952	L.H. pigtail with turn signals	24.50 ea.
FAC-13203-AR	1953	R.H. pigtail with turn signals	21.00 ea.
FAC-13203-AL	1953	L.H. pigtail with turn signals	20.00 ea.

Junction Block Wiring

Mount front corners of core support	1949-53		
FDT-14448-A	No turn signal		25.00 ea.
FDT-14448-B			25.00 ea.
FDT-14448-C	With turn signal		25.00 ea.

Turn Signals

BA-14435-A	1949-50	turn signal wire from dash to left rear of car with loom	27.00 ea.
0A-14492	1949-50	switch to turn indicator less switch and flasher	46.00 ea.
0A-14499	1949-54	front turn signal wire	27.00 ea.
1A-14404-A	1951	turn signal flasher wires less flasher	33.00 ea.
1A-14486-A	1951	turn signal switch wires	23.00 ea.
FAC-14486-B	1952-54	turn signals switch wires	23.25 ea.
FAB-14404-A	1953	turn flasher wires	47.00 ea.

Heater Wires

8A-14309-MU	1949	heater switch to signal speed motor	6.00 ea.
0M-14309-A	1949-50	heater switch to ignition with in line fuse	24.00 ea.
8M-14309-A	1949-50	heater switch to ing. no fuse	4.00 ea.
B4AZ-18A627-MU	1949-54	heater switch to motor wires	12.00 ea.
1A-14309-C	1951	heater wire harness	33.50 ea.
FAA-14309-A	1952-53	heater switch to motor wire	13.00 ea.
FAB-14309-A	1952-53	power feed with inline fuse	23.00 ea.

License Light Wires

7RA-13412	1949-51	pigtail & socket	10.00 ea.
FAA-13560-A	1952-54	wire for license light	11.00 ea.
OA-14415	1950-51	license wire in trunk lid	5.00 ea.
8A-14415	1949	license wire in trunk	5.00 ea.

Clock Wires

8A-15026-CS	1949-50	clock light wire and sockets	15.25 ea.
8A-15026-EWO	1949-51	electric clock feed wire less fuse	4.00 ea.
8A-15026-E	1949-51	1 clock feed wire with fuse	29.00 ea.
FAA-15026-A	1949-53	wind up clock light	9.00 ea.
FAA-15026-C	1952-53	electric clock feed wire	23.50 ea.

Wire Harness Grommet

Used where wiring passes through fender panels & radiator panels. Metal grommet coated with vinyl.

352873-L			4.00 ea.
----------	--	--	----------

Overdrive Wires

8M-6917-W	1949-50	overdrive lock out switch	5.75 ea.
8M-14381	1949-51	overdrive wire relay to coil	4.00 ea.
8M-14382	1949-50	overdrive harness except convt.	35.75 ea.
8M-14396	1949-51	ign. switch to overdrive relay	4.50 ea.
FAA-14382-A	1952-53	overdrive wire 41" long	25.00 ea.
FAC-14382-A	1952-54	overdrive wire 53" long	28.25 ea.
FAA-14396-A	1952-54	overdrive relay to switch	4.00 ea.
FAA-14381-A	1952-54	overdrive relay to coil wire	4.00 ea.
1A-14382-A	1951	overdrive harness	33.00 ea.

Dome and Courtesy Lights

FAC-13796-A	1949-55	dome light wire	3.25 ea.
1A-13796	1951	Victoria dome light wire	5.00 ea.
1A-14328-WS	1951	convt./Victoria courtesy lamp wire with socket	35.00 ea.
0A-14335	1951	R.H. to L.H. dome light wire	7.00 ea.
FAB-14318	1953	convt. & Victoria dome light feed wire	2.50 ea.
FAA-14328-C	1952-53	courtesy lamp	30.00 ea.
FAB-14328-B	1953	courtesy lamp wire convt. & victoria	49.00 ea.
OA-14328-A	1950-51	mainline & customline courtesy lamp harness	28.50 ea.
OA-14328-B	1950	courtesy lamp convt.	50.00 ea.
1A-14318	1951	Victoria & convt. dome light feed wire	2.50 ea.
8A-13796-A	1949, 1952-53	pillar switch wire	5.00 ea.
8M-13713	1949-53	courtesy lamp switch	8.00 ea.

Radio Wires

8A-18805-W	1949-50	radio feed wire	6.25 ea.
1A-18805-W	1951	radio feed wire	6.00 ea.
FAA-18805-W	1952-53	radio feed wire	6.25 ea.

Convertible Top Wiring

FAB-14351-A	1952-53	top control circuit breaker to solenoid	9.00 ea.
FAA-14362-A	1952-53	top relay to breaker wires	24.00 ea.
51A-14332-A	1946-49	top switch to breaker wire	15.00 ea.
8A-14506		starter solenoid to top pump	10.00 ea.
1A-14351	1951	circuit breaker to solenoid	8.00 ea.
1A-14348	1951	switch to solenoid	12.00 ea.

Most orders shipped same day!

We accept



Misc Wires

7RA-14302	1949-54	coil-distributor wire	3.50 ea.
51A-14432	1949-53	temp sender cross wire	5.00 ea.
8A-14441	1949-50	dimmer switch to dash	15.00 ea.
8A-14475	1949-53	stop light switch wire	13.50 ea.
8A-9272-B	1949-50	instrument cluster wire	6.00 ea.
FAB-9272-A	1952-53	instrument cluster wire	6.00 ea.
8A-15053	1949	cigar lighter wire	2.50 ea.
1A-14476	1951	neutral safety switch harness	7.75 ea.
1A-18256-A	1951	trunk light wire	16.25 ea.
8A-14406	1949-50	fuel tank wire	12.00 ea.
1A-14406	1951	fuel tank wire	4.50 ea.
FAA-14429-A	1952-54	circuit breaker to cigar lighter	2.75 ea.
8A-14303	1949-51	engine to firewall gnd. convertible only	7.25 ea.
FAA-14476-A	1953-53	neutral switch wire	6.75 ea.
FAB-14406-B	1952-53	fuel tank feed wire	3.25 ea.

Backup Lights

8A-18274	1949-51	R.H. light wire with socket	17.00 ea.
8A-18275	1949-51	L.H. light wire with socket	26.75 ea.
FAB-15506-B	1952-53	switch to lamp harness	17.75 ea.
FAB-15536-A	1952-54	socket and wire	2.50 ea.

Wire Connectors

B-14487	female both ends pak of 10	5.50 pak
B-14486	male single end pak of 10	3.50 pak
59A-14487	4-way connectors	2.00 ea.

ANTI-SQUEAK MATERIAL

8M-16070-A 15 foot roll. 20.00 roll

Ford and Mercury

This part is made of rubber with grooves in it and is used in the following places:

Clutch shield to frame	36"	1949-51
Front bumper stone deflector	36"	1949
Front fender apron splash panel	36"	1949-51
Cowl side panel to fender filler	36"	1949-51
Front fender apron splash panel	10-1/2" outer	1949-51
Front fender apron splash panel	14" front	1949-51
Clutch pedal shield to dash panel	16"	1949-51
Clutch shield to frame	8"	1949-51
Cowl side panel to fender filler	10-1/4"	1949-51

FRONT FENDER PARTS

Die Cast Emblems

1BA-16237-PR	1951-53 chrome plated V8 emblems	40.00 pr.
OA-16079	1950-51 Crestliner fender script (gold)	50.00 ea.



Miscellaneous Fender Parts

BA-16126-A	1952-56 top back of front fender to cowl pad	5.00 pr.
BA-16170-A	1952-54 anti-squeak seal front fender, goes from splash apron to fender and rear of splash apron to body	15.00 kit
BA-16254	1952-53 front fender to splash apron weather strip	20.00 ea.
8A-16254-S	1949 front fender to splash apron weather strip	3.00 ea.

Fender Skirts

These are die stamped steel with three ribs just like the originals. Sold in pairs.

8A-27274-5-70	1949-51 Ford cars	140.00 pr
01A-18990	fender skirt rubber seal	10.00 ea.

Fender Mouldings

This moulding is the front spear of the body side mouldings. Polished stainless steel.

8A-16003	1949-50 R.H.	50.00 ea.
8A-16004	1949-50 L.H.	50.00 ea.

Side Moulding Retaining Clip

2478	1955-56 Ford car rear quarters, rear doors	2.00 ea.
------	--	----------

Front Fender Gravel Shield

The gravel shield is mounted just behind the front tire on the fender. Made of polished stainless steel.

1A-18268	1949-51 sold in pairs	130.00 pr.
----------	-----------------------	------------

Front Fender Splash Seal Kit

BA-16254-A	1952-53 6 piece kit	20.00 set
------------	---------------------	-----------

HOOD PARTS**Hood Emblems**

0A-16637-B	1950-51	emblem	45.00 ea.
0A-16644-B	1950-51 USA	chrome emblem bezel	40.00 ea.
BA-16637-A	1952-56	(custom line) emblem	45.00 ea.
BA-16644-A	1952-54 USA	chrome emblem bezel	45.00 ea.
0A-16675	1950-54	hood emblem pad	1.00 ea.
8A-16606-S	1949	hood letters	47.50 set

**Hood Ornament Plastic Insert**

This is the clear plastic insert that sticks up from the ornament.

8A-16852	1949	8.50 ea.
0A-16852	1950	8.50 ea.
1A-16852	1951	10.00 ea.

Cowl Lacing

These kits include all hardware.

8A-16740-B	1949-51	7.00 ea.
BA-16740-B	1952-54	9.00 ea.
8M-16740	1949-51 Merc.	8.00 ea.

Most orders shipped same day!

We accept



Hood Bumpers

These are complete kits with all the bumpers.

8A-16761-S	1949	4 pieces	7.50 kit
0A-16761-S	1950-51		10.00 kit
BA-16761	1952-54		16.50 kit
8M-16761	1949-51	Mercury	8.00 kit

1949-50 Center Hood Trim Strip

These are polished stainless steel.

8A-16736	1949-50		40.00 ea.
----------	---------	--	-----------

Hood Hinge Spring

8A-16789	1949		11.00 ea.
0A-16789	1950		11.00 ea.

Hood Safety Catch Spring

11A-16897	1949-50		10.00 ea.
8M-16897-B	1951-52	Ford car, 49-51 Mercury (with pin)	7.50 ea.
51A-16897	1949-50	(with pin)	7.00 ea.

Hood Release Pull Cable

8A-16916-C	1949-51	with chrome HOOD knob cut to length	30.00 ea.
8A-14605-A	1949-51	hood cable grommet	2.00 ea.

Hood Hinge Shoulder Bolts

These are the special bolts to attach the hood hinge to the hood.

8A-16798-S	1949-53	4 per car	3.00 ea.
BA-16878-A	1952-54	hood hinge to body pads	15.00 pr.

SPEEDOMETER CABLE

A9A-17260	1949-53	standard transmission	20.00 ea.
B1A-17260	1951	with auto trans.	16.00 ea.
8A-17265-S	1949-51	grommet	3.00 ea.

Speedometer Drive Gears car and pickup

B5A-17322-A	49-72	20 teeth blue color	10.00ea
B5A-17322-B	49-72	21 teeth green color	10.00 ea.
B5A-17322-C	49-72	19 teeth brown color	10.00 ea.
B5A-17322-D	49-72	22 teeth clear/transparent	10.00 ea.

BUMPER PARTS

Bumper Stone Guard-Splash Apron Parts

8A-16254-S		rubber front splash apron to radiator seal	3.00 ea.
8A-17749	1949	front stone deflector to bumper arm grommets 2 per kit	3.50 kit
0A-17749	1950	front stone deflector to bumper arm grommets 4 per kit	4.50 kit
1A-17749	1951-55	front stone deflector to bumper arm grommets 2 per kit	4.50 kit
8A-17832-A	1949	rear stone deflector to bumper seal	20.00 ea.
0A-17832	1950-51	rear stone deflector to bumper seal	10.00 ea.
BA-17832	1952-54	rear stone deflector rubber between body and rear bumper	18.00 ea.

HEATER AND RELATED PARTS

1949-51 Heater Parts

0A-17513-B	1950	heater knob ivory	5.50 ea.
0A-17513-C	1950	heater knob black	6.00 ea.
0A-18547-B	1950	air vent knob ivory	5.50 ea.
0A-18547-C	1950	air vent knob black	6.00 ea.
8A-18551	1949-51	molded hose for heater temp control valve	10.00 ea.
BPA-18572	All	heater hose clamps all models	1.00 ea.
8A-18584-B	49-51	heater blower housing to airduct valve hose	4.00 ea.
8A-18594	49-51	heater motor housing to firewall seal	5.00 ea.
8A-18594-C		heater core housing to firewall seal	5.00 ea.
8A-18596		heater core tubes to firewall seals	6.00 pr.
8A-14605-B		heater motor wire grommet at firewall	1.00 ea.
8A-18555-S		heater hose kit 1949-51	20.00 kit

1952-53 Heater Parts

B6A-18489-A	heater square connecting duct hose to blower duct	1952-56	15.00 ea.
FAA-8725-A	clamp retainer for square heater air duct	1952-56	4.00 ea.
BA-18568	heater housing to core gasket	1952-56	6.00 ea.
BA-18570	heater to firewall seal	1952-56	6.00 ea.
FAD-18583	heater motor to housing seal	1952-59	7.00 ea.
B5A-18584-A	round duct heater to air valve	1952-56	15.00 ea.
FAB-19203-A	knob heater door black	1952-57	7.50 ea.

Air Vent System

8A-7001862-S	1949-56	air valve dampener rubber only, you must drill spot welds to replace.	15.00 pr.
8A-7001878	49-51	air vent to duct hoses at inner fenders	8.00 pr.
8A-7001880	49-51	air vent assy. to firewall seal	8.00 pr.
BA-7001880-A	52-54	vent air valve gasket	8.00 pr.
BA-7001878-C	52-54	air duct connecting tube	15.00 pr.
8A-8716	49-50	fresh air duct screen-front	15.00 pr.
A-7001909	1951	fresh air duct screen-front	15.00 pr.
8M-8716	1949	Ford & Merc. fresh air duct screen-front	15.00 pr.
0M-7201900	1950-51	Ford & Merc. fresh air duct screen-front	15.00 pr.

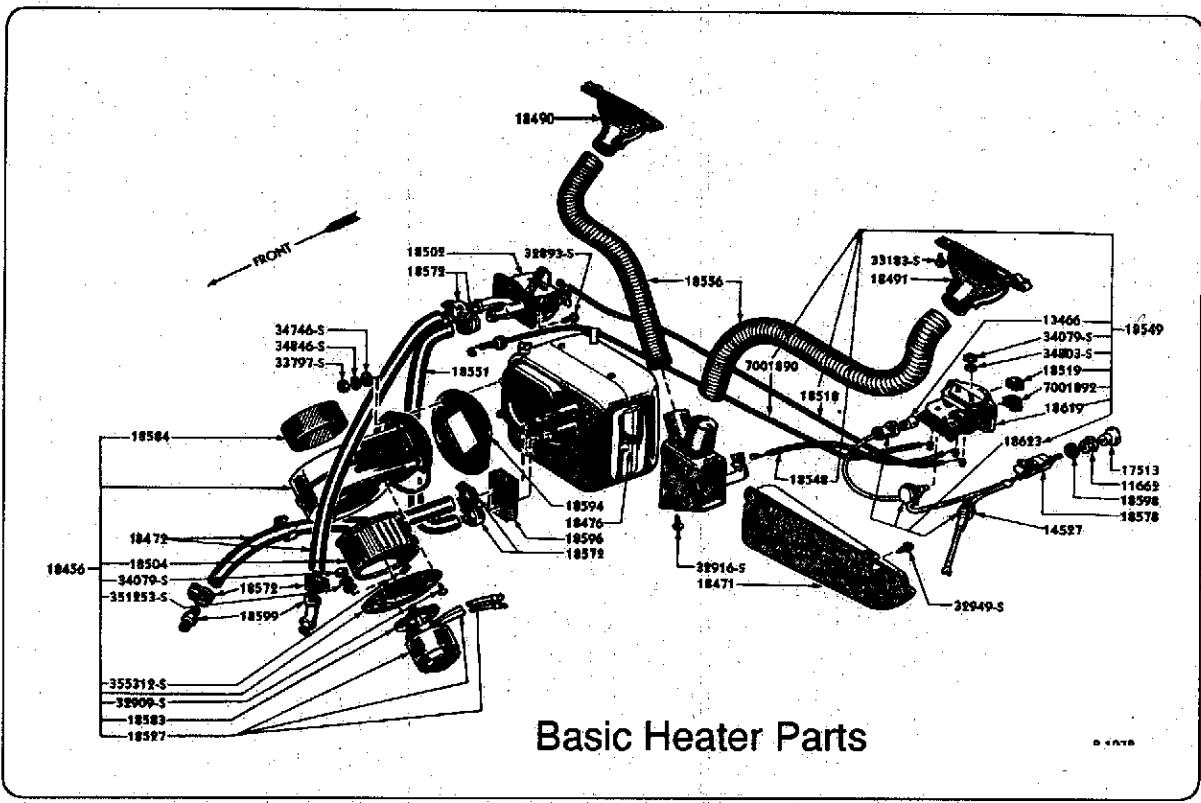

Basic Heater Parts

Antenna

8A-18813	1949-51	top of cowl mount exact copy of original	72.50 ea.
B5A-18813-C	1952-56	car antenna	70.00 ea.

Radio Knobs

8A-18805	1949-50	radio knobs for 5 button	30.00 set
8A-18809-S	1949-50	radio face for 6 button	18.00 ea.

Radio Instruction Books

RB-49	1949	4.00 ea.
RB-50C	1950 custom	4.00 ea.
RB-50D	1950 deluxe	4.00 ea.
RB-51C	1951 custom	4.00 ea.
RB-51D	1951 deluxe	4.00 ea.
RB-52	1952	4.00 ea.
RB-53	1953	4.00 ea..

Most orders shipped same day!

We accept



FIREWALL PARTS

Firewall Insulators for 1949-53 Cars

The following firewall covers are made of ABS plastic. A high-tech photoengraving process is used to faithfully reproduce the original chicken track texture that was used on 1949-53 Ford cars. These firewall insulators are complete units ready to install. No holes to drill, a preassembled unit including sound board and insulation. The best available.

48-7001670	firewall cover clip	3.00 ea.
8A-100	1949-50 square hump for trans tunnel	200.00 ea.
1A-100	1951 cars	200.00 ea.
FAA-100	1952-54 cars	200.00 ea.

Grommets

1A-7001694	1951-59 overdrive cable grommet	5.00 ea.
1A-14567	1951 overdrive relay grommet	3.00 ea.
8A-14605-A	1949-51 hood cable grommet	2.00 ea.
B-14605-A	1949-51 air vent cable grommet	2.00 ea.
B-14607	1949-51 choke cable grommet	1.00 ea.
8A-17545-S	1949-51 wiper hose grommet	3.00 ea.
8A-17265-S	1949-51 speedometer cable grommet	3.00 ea.
8A-14603-B	1949-50 Ford 49-51 Merc. main wire loom grommet	4.00 ea.
1A-14603-B	1951 main wire loom grommet	4.00 ea.
OA-2273	1949-50 hand brake cable grommet	12.50 ea.
8A-14605-B	1949-51 heater motor wire grommet	1.00 ea.
1A-14567	1951 overdrive relay wire grommet	3.00 ea.
8A-14608	main wire loom grommet retainer Ford & Merc.	10.00 ea.

Patent Plates

8A-14001	1949-50 includes installation hardware	6.00 ea.
8M-14001	1949-50 Mercury includes hardware	8.00 ea.

COWL KICK PANELS

8A-7002341	1949-50	15.00 pr.
1A-7002341	1951	15.00 pr.

SUNVISORS

8A-7004104	1949-51 all except wagon and convertible	30.00 ea.
8M-7004104	1949-51 Mercury all except convertible and wagon	22.50 ea.
8A-7004144-CP	1949-50 sunvisor bracket, closed car, plain	25.00 ea.
8A-7004144-CC	1949-50 sunvisor bracket, closed car, chrome	30.00 ea.
1A-7004144-AP	1951 except convt., Victoria & wagon visor bracket plain	25.00 ea.
1A-7004144-CC	same as above except chrome plated	30.00 ea.
1A-7604144-AP	1949-51 convt. & 1951 Victoria, plain	25.00 ea.
1A-7604144-CC	same as above except chrome plated	30.00 ea.
BA-7004104-A	1952 2 door and 4 door light gray	20.00 ea.
BF-7004104-A	1953 2 door and 4 door light gray	20.00 ea.
BA-7604144-BP	1952-54 right hand sunvisor arm painted, convertible	50.00 ea.
BA-7604145-BP	1952-54 left hand sunvisor arm painted, convertible	50.00 ea.
BA-7604144-CC	1952-54 right hand sunvisor arm chrome, convertible	60.00 ea.
BA-7604145-CC	1952-54 left hand sunvisor arm chrome, convertible	60.00 ea.

DASH TRIM AND KNOBS

Turn Signal knobs

0A-13305-B	1949-51	ivory color	6.00 ea.
0A-13305-C	1949-51	black color	6.00 ea.

Interior Light Switch Knob

0A-13755-B	1950	ivory	5.50 ea.
0A-13755-C	1950	black	6.00 ea.

Miscellaneous Knobs

0A-7030710-B		ivory	rear ash tray knobs	5.50 ea.
0A-7030710-C	1950	black	rear ash tray knob	5.50 ea.
0A-7023341-BS		ivory	window crank knob	5.50 ea.
0A-7023341-CS		black	window crank knob	6.00 ea.
8A-7021850-B	1949-51	dark gray	door lock button	6.00 ea.
8A-7023341-D	1949		window crank knob	5.50 ea.
1A-7023352	1951-56	black	window crank knob	6.00 ea.

1950 Dash Knobs

0A-11661-B	ivory	headlight switch w/shaft	9.00 ea.
0A-11661-C	black	headlight switch w/shaft	9.00 ea.
0A-17513-B	ivory	wiper switch knob	5.50 ea.
0A-17513-C	black	wiper switch knob	6.00 ea.
0A-9700-B	ivory	choke knob	5.50 ea.
0A-9700-C	black	choke knob	6.00 ea.
0A-15052-B	ivory	cigar knob	7.00 ea.
0A-15052-C	black	cigar knob	7.50 ea.
0A-13755-B	ivory	interior light knob	5.50 ea.
0A-13755-C	black	interior light knob	6.00 ea.
0A-18547-B	ivory	air vent knob	5.50 ea.
0A-18547-C	black	air vent knob	6.00 ea.
0A-17513-B	ivory	heater knob	5.50 ea.
0A-17513-C	black	heater knob	6.00 ea.
0A-7213	ivory	shift knob	7.00 ea.
0A-7213-C	black	shift knob 1949-53	7.00 ea.

Complete Knob Kits for 1950

0A-9270-BS	set of 8 listed above for closed cars except crestliner	45.00 set
0A-9270-CS	convertible only	set of 8 45.00 set
0A-9270-DS	crestliner only	set of 8 47.50 set

1950 Chrome Dash Ends

0A-7004404-PR	1950 car dash end tips	65.00 pr.
---------------	------------------------	-----------

Dash/Roof Side Emblems

1A-700450-A	1951 dash bezel, 51-54 Vicky roof side bezel gold	32.00 ea.
1A-7004359	1951 dash emblem, 51-54 Vicky roof side emblem	35.00 ea.

Most orders shipped same day!

We accept



Dash Bezels (die cast chrome)

8A-18598-A	49-50*	heater switch bezel "BLOWER" in black letters	20.00 ea.
8A-18598-B	1949	defroster bezel "DEFROSTER" in black letters	20.00 ea.
8A-18598-C	1949	temp. bezel "TEMPERATURE" in black letters	20.00 ea.
8A-18598-E	1949*	headlight switch bezel "LIGHTS" in black letters	15.00 ea.
8A-18598-F	1949-50*	wiper switch bezel "WIPERS" in black letters	15.00 ea.
8A-18598-G	1949-51	overdrive bezel "OVERDRIVE" in black letters	15.00 ea.
8A-18598-H	1949-50*	choke bezel "CHOKE" in black letters	15.00 ea.
0A-18598-A	1949-50*	air vent bezel "AIR" in black letters (takes 2)	15.00 ea.
0A-18598-B	1950	(except conv. & wagon) interior light switch bezel "INTERIOR LIGHTS" in black letters	15.00 ea.
1A-10853-A	1951	(except wagon) fits headlight, choke, interior light, wiper, & ignition (5 per car)	Call
1A-7004646-A	1951	(except wagon) cigar lighter bezel polished SS	Call

*Also fits 1951 wagon

WINDSHIELD SEALS

8A-7003110-D	1949-51	no chrome all closed cars except Victoria	85.00 ea.
8A-7003110-E	1949-50	single groove for chrome strip body styles 70-B,72-B,73-B	85.00 ea.
0A-7003110	1950-51	double groove for chrome strip closed cars except Victoria	85.00 ea.
0A-7603110	1950-51	convt., and 51 Victoria double groove	85.00 ea.
8A-7603110-B	1949-51	convertible and 51 Victoria single groove	85.00 ea.
BA-7603110-D	1952-54	2-door hardtops & convertible	70.00 ea.
BA-7003110-E	1952-54	without groove for trim fits mainline - 2dr., 4 dr., wagon and business coupes	70.00 ea.
BA-7003110-F	1952-54	with groove for trim fits customline- 2 dr., club coupe, 4 dr., crestliner- 4 dr.	70.00 ea.
8M-7003110		1949-51 Mercury all except wagon	90.00 ea.



Garnish Moldings to Dash Rubber

BA-7003127-A	1952-55 car	82" long	8.50 ea.
--------------	-------------	----------	----------

Header Bow Seals

0A-7603476	1949-51	attaches on top of windshield	32.50 ea.
------------	---------	-------------------------------	-----------

GLOVE BOX

Glove Boxes

8A-7006010	1949-50 & 51	wagons	30.00 ea.
1A-7006010	1951	except wagon	30.00 ea.
BA-7006010-A	1952-53		25.00 ea.
8M-7006010	1949 Merc.		40.00 ea.
0M-7006010	1950-51 Merc.		20.00 ea.

Glove Box Parts

8A-7006066	1949	door bumpers	2.00 pr.
0A-7006066	1950	door bumpers	2.00 pr.
1A-7006066	1951	door bumpers	3.00 pr.
0A-16378	1952-59	door bumpers	3.00 pr.
DF-129	1949-51	glove box decal (tire pressures)	3.50 ea.
8A-7006122	1949-56	door check arm grommet	2.50 ea.
0M-7206122	1949-51 Merc.	check arm grommet	5.00 ea.

FLOOR PARTS

Floor Mats

0A-7013000-A	1949-50	with jute backing exact reproduction	140.00 ea.
1A-7013000-B	1951	with jute backing (does not have Ford Crest)	140.00 ea.
BA-7013000-B	1952-54	front mat with jute backing	100.00 ea.

Floor Plugs

352291-S	3/4" hole	2.00 ea.
352284-S	1-1/4" hole	2.00 ea.
352285-S	1-1/2" hole	2.00 ea.
357216-S	1 3/4" hole	2.00 ea.

Transmission Inspection Grommet (in floor)

8A-7012115-S	1949-50	2 per car	5.50 pr
1A-7012115	1951	4 per car	6.50 set

Master Cylinder Floor Cover

91A-7011136	1949-51	cars	7.50 ea.
-------------	---------	------	----------

Accelerator Pedal Rod Seal at Floor

8A-7012177-S	1949-51	cars	3.00 ea.
--------------	---------	------	----------

Most orders shipped same day!

We accept



DOOR PARTS

Scuff Plates

The scuff plates are the trim panel under the door on top of the rockers.

8A-7013208-PR	1949	tudor sedan, coupe & convt.	110.00 pr.
0A-7013208-PR	1950	tudor, coupe & convt.	110.00 pr.
8A-7313208-PR	1949	fordor front doors	110.00 pr.
8A-7313228-PR	1949	fordor rear doors	110.00 pr.
0A-7313208-PR	1950	fordor front doors	110.00 pr.
0A-7313228-PR	1950	fordor rear doors	110.00 pr.
1A-7013208-PR	1951	tudor body styles	120.00 pr.
BA-7013208-PR	1952-54	tudor	110.00 pr.
BA-7313208-PR	1952-54	fordor front doors	110.00 pr.
BA-7313228-PR	1952-54	fordor rear doors	110.00 pr.

Door Seals

Each kit has pre-molded seals for all doors on the car.

8A-7020530-PR	1949-51	tudor closed cars	100.00 kit
8A-7320530-SET	1949-51	fordor closed car	190.00 kit
8A-7620530-PR	1949-51	convertible & victoria	120.00 kit
8A-7920530-PR	1949-51	wagon	120.00 kit
BA-7020530-PR	1952-54	tudor sedans	100.00 kit
BA-7620530-PR	1952-54	convt. & victoria	100.00 kit
BA-7320530-SET	1952-54	fordor all doors	225.00 kit
8M-7320530-PR	1949-51	Merc. fordor	200.00 kit
8M-7020530-PR	1949-51	Merc. tudor	120.00 kit
8M-7620530-PR	1949-51	Merc. convertible	120.00 kit

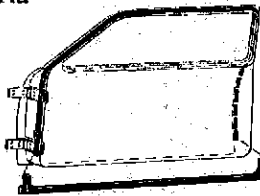

Coat Hanger	1953-67 with screw	10.00 pr.
--------------------	--------------------	-----------

Door Seal Retainer

This is the scalloped strip of metal welded to the bottom of the door which holds the door seal in place.

8A-7020712-PR	1949-51 all cars	8.00 pr.
---------------	------------------	----------

Door Lock Button

8A-7021850-B	1949-51	gray color	6.00 ea.
8M-7221999	1952-56	lock button grommet	3.00 ea.

Door Window Channel Kits

These kits are complete felt kits for the door glass to run as it rolls up and down. Very nice kits. Each kit has enough parts for two doors or windows.

There are two different styles used by Ford in 1950 and 1951. The major difference to look for is the division bar between the door glass and the vent window assembly. Some have a steel track with a stainless bead and the others have a fabric channel.

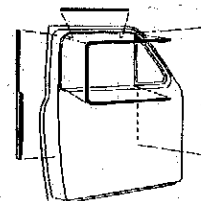
**Coupe and Tudor**

8A-45983-2D	1949	front doors fabric division bar	100.00 kit
0A-45983-2D	1950	front doors fabric division bar	100.00 kit
1A-45983-2D	1950-51	front doors steel division bar	100.00 kit
1A-45983-V	1951	Victoria only	250.00 kit

Fordor Cars

8A-45983-4D	1949	front doors fabric division bar	100.00 kit
8A-56791	1949	rear doors	88.00 kit
0A-45983-4D	1950	front doors fabric division bar	100.00 kit
1A-45983-4D	1950-51	front doors steel division bar	100.00 kit
1A-56791	1950-51	rear doors	88.00 kit

Tudor Rear Quarter Windows

8A-56786	1949	channel kit	92.75 kit
0A-56786	1950	fabric division bar	80.00 kit
1A-56786	1950-51	steel division bar	92.75 kit

Window Regulator to Glass Track Clip

11A-7023257	1941-53 hair pin clip		.50 ea.
-------------	-----------------------	--	---------

Station Wagon Sliding Quarter Window Channel Kit

Includes fabric lined glass runs, rubber window seals & vertical anti-rattles. Does 2 sliding windows.

0A-56791-W	1950-51 Ford & Merc station wagon w/ sliding rear quarter windows	300.00 kit
------------	---	------------

Station Wagon Door Window Anti-Rattle Kit

Includes fabric lined division bars w/lower brackets, glass runs & inner/outer anti-rattles. Does 2 doors.

0A-45983-W	1950-51 Ford & Merc station wagon	200.00 kit
------------	-----------------------------------	------------

Most orders shipped same day!

We accept



Door and Quarter Glass Lift Channels

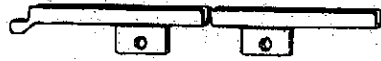

Front Doors

8A-7021454-A	1949 front door r.h. tudor sedan and coupe	25.00 ea.
8A-7021459-A	1949 front door l.h. tudor sedan and coupe	25.00 ea.
8A-7021458-B	1950-51 r.h. or l.h. front door tudor and coupe	20.00 ea.

Door and Quarter Glass Lift Channels Continued

8A-7321458-A	1949 R.H. fordor front door	25.00 ea.
8A-7321459-A	1949 L.H. fordor front door	25.00 ea.
8A-7321458-B	1950-51 fordor L.H. or R.H.	20.00 ea.
8A-7621458-A	1949-51 R.H. front door convt. and victoria/hardtop	25.00 ea.
8A-7621459-A	1949-51 L.H. front door convt. and victoria/hardtop	25.00 ea.

Rear Door Window Lift Channels

8A-7326228-A	1949 rear door R.H.	20.00 ea.
8A-7626229-A	1949 rear door L.H.	20.00 ea.
8A-7326228-B	1950-51 rear door left or right	20.00 ea.

Quarter Window Lift Channels

8A-7029900-A	1949-51 quarter glass R.H.	20.00 ea.
8A-7029901-A	1949-51 quarter glass L.H.	20.00 ea.

Roller Kit Window Regulator

BA-7023240-A	roller and spring assy. 53-56 (2 per regulator)	7.50 ea
--------------	---	---------

1953-54 Window Lift Channel Weatherstrip

BA-7621478-C	1 per door needed	6.00 ea.
--------------	-------------------	----------

Door Panel Clips

B-20015	1949-59 set of 50	12.00 set
---------	-------------------	-----------

Door Garnish Molding Emblems

8A-7020988-9A	1949 plastic emblem	60.00 pr.
0A-7020988-9A	1950 closed car gray color	60.00 pr.
0A-7020988-9B	1950 convt. black color	60.00 pr.
8A-7020988-PR	1949 door emblem plastic holder chrome	70.00 pr.

Door Vent Window Seals

8A-7021448-PR	1949-51	tudor, club coupe & fordor	85.00 pr.
8A-7621448-PR	1949-early 1950	convertible	140.00 pr.
0A-7621448-PR	late 1950-51	convt. & Victoria	140.00 pr.
BA-7021448-PR	1952-54	all closed cars	100.00 pr.
BA-7621448-PR	1952-54	convt. & Victoria	110.00 pr.
8M-7021448-PR	1950-51	Merc. closed cars	100.00 pr.

Back Edge of Vent Window Seals

8A-7021450-PR	1949-51	tudor, coupe, fordor	20.00 pr.
8A-7621450-PR	1949-51	convt. & victoria	20.00 pr.
BA-7021450-PR	1952-54	tudor and fordor	20.00 pr.
BA-7621450-PR	1952-54	convt. & hardtop	20.00 pr.
8M-7021450-PR	1950 Merc.	closed cars early	30.00 Pr.
0M-7221450-PR	1950-51 Merc.	closed cars	25.00 pr.

Vent Window Handles These include the lock button

A9AZ-7022916-A	1949-56	right hand	30.00 ea.
A9AZ-7022917-A	1949-56	left hand	30.00 ea.

Vent Handle Lock Button Kit

Each kit has enough parts for one handle.

8A-7022920-S	1949-56		5.00 ea.
--------------	---------	--	----------

Vent Window Handle Shaft Brackets

8A-7022938-B	1949-56	right hand door	15.00 ea.
8A-7022939-B	1949-56	left hand door	15.00 ea.
78-7022916	1949-51	rear vent window coupe	30.00 ea.
78-7022917	1949-51	rear vent window coupe	30.00 ea.

1950-51 Vent Window Pivots

These are the male sides for the convertibles and Victorias.

8A-7622978-B	1950-51	right hand side	20.00 ea.
8A-7622979-B	1950-51	left hand side	20.00 ea.
8A-7621466-A	1950-51	female pivot right side	20.00 ea.
8A-7621467-A	1950-51	female pivot left side	20.00 ea.
8M-7022916	1949-51	Mercury right hand side	30.00 ea.
8M-7022917	1949-51	Mercury left hand side	30.00 ea.

Vent Window Pivot Spring and adjustment hole plug

B5A-7022926-A	1953-56 and 1955-56	Mercury exp. Wagon	5.00 ea.
352285-S	1953-56	vent window frame adjustment hole plug 1-1/2"	2.00 ea.

Lock Cylinder

BAAA-7022050-S	Doors & ignition, matched set	1952-56 car	50.00 set
B7A-7021984-A	Doors only, matched set	1952-56 car	40.00 set.

Outside Door Handles

These handles are die cast chrome like the originals. The handle does not include the push button.

0A-7022400	1950-51	right side	70.00 ea.
0A-7022401	1950-51	left side	70.00 ea.
BA-7022400-C	1952-56	right hand	70.00 ea.
BA-7022401-C	1952-56	left hand	70.00 ea.

Outside Door Handle Push Buttons

Includes button, spring and adjuster.

0A-22454-70	1950-51	left or right	15.00 ea.
BA-22454-70B	1952-56	right hand side	15.00 ea.
BA-22455-70B	1952-56	left hand side	15.00 ea.

Most orders shipped same day!

We accept



Door Handle and Lock Pads

0A-7022428	1950-51	set of 4 pieces except wagon door handle pads	8.00 set
0M-7222428	1950-51	wagon and 50 Mercury handle pads	7.50 set
BA-7222428	1952-56	handle pad kit	6.00 set
8A-7021985-S	1949-51	door lock cyl. to door pads	5.00 pr.

Door Lock Parts

B2A-7021942-A	1953-56	R.H. lock cover with spring	11.00 ea
B2A-7021943-A	1953-56	L.H. lock cover with spring	11.00 ea
B7A-7022075-A	1956-56	lock cover spring only	2.50 ea

Inside Window Riser Handle

8A-7023342-C	1949	window crank chrome knob	20.00 ea.
8A-7023342-D	1949	window crank lt. gray knob	20.00 ea.
0A-7023342-B	1950	window crank ivory knob	20.00 ea.
0A-7023342-C	1950	window crank black knob	20.00 ea.
B5A-7023342-A	1951	window crank handle	25.00 ea.
357550-S	1951-59	door handle retaining clip	.60 ea.
1A-7630322	1951-56	1/4 window handle convertible and Victoria	30.00 ea

Inside Door Handles

8A-7022614-A	1949	door opening handle	17.50 ea.
0A-7022614-B	1950	door opening handle	17.50 ea.
B5A-7022600-A	1951-56	door opening handle	23.00 ea.

Escutcheons Inside Door Handles

0A-7022618-F	1949-50	spring loaded stainless steel	12.00 ea
--------------	---------	-------------------------------	----------

Door Striker Plates

BA-702340-L	1950-54	left side	15.00 ea.
BA-702340-R	1950-54	right side	15.00 ea.
353382-S	1950-54	striker plate bolt	.50 ea.
BA-7022058-A	1950-54	striker plate shim	4.00 ea.

Arm Rests

BAAA-8124141	1949-51	front or rear	50.00 pr.
--------------	---------	---------------	-----------

Door Hinge Parts

354488	hinge to post or door screw with washer	1.30 ea.
HD-1167-A	hinge pin 1949-51	1.00 ea.

REAR QUARTER WINDOW PARTS**Window Seals**

8A-7229405-PR	1949-51	business coupe stationary window	40.00 pr.
8A-7030248-PR	1949-51	tudor sedan rear pop-out window seals	120.00 pr.
0A-7229904-PR	1949-51	club coupe push out window seals	120.00 pr.
8A-7030238-PR	1949-51	tudor sedan, coupe back edge of pop-out window seals	20.00 pr.
BA-7629746-PR	1952-54	convt., victoria front of window pads	25.00 pr.
BA-7229904-PR	1952-54	coupe stationary window seals	60.00 pr.
BA-7630146-S	1952-56	front of 1/4 window seal	25.00 pr.
0A-7030248-PR	1949-51	tudor stationary quarter window seals	50.00 pr.

REAR WINDOW SEALS

8A-7042084	1949-51	closed car no chrome	60.00 ea.
8A-7042084-D	1949-51	single groove for chrome	60.00 ea.
0A-7042084	1949-51	double groove for chrome	60.00 ea.
1A-6042084-A	1951	Victoria	140.00 ea.
BA-6042084-E	1952	crestline 2-door hardtop	160.00 ea.
BA-7042084-E	1952-54	mainline tudor, fordor, coupe	70.00 ea.
BA-7042084-F	1952-54	customline tudor, fordor, club coupe,	
		crestline fordor	70.00 ea.
8M-7242084-B	1949-50	Merc. one piece glass	65.00 ea.
1M-7042084	1951	Mercury includes locking strip	87.50 ea.



No Chrome



Single Groove



Double Groove



TRUNK LID PARTS

Trunk Lid Hinges

These are die cast chrome plated and very nice.

8A-7042700-PR	1949 car	110.00 pr.
0A-7042700-PR	1950 car	115.00 pr.

Trunk Hinge to Body Pads

8A-7042707-A	1949	four pieces		6.00 set
0A-7042707-B	1950	four pieces		6.00 set

Trunk Lid Emblems

0A-7042514-B	1950-54	plastic insert	45.00 ea.
1A-7043500	late 1950-54	emblem bezel die cast chrome plated	38.50 ea.
BF-7043522-A	1953-54	trunk lid bezel	45.00 ea.
BF-7042527-A	1953-55	"Fordomatic" script, includes fasteners.	25.00 ea.

Deck Emblem Pads

0A-16675	1950-51	pad goes behind plastic insert	1.00 ea.
BA-7043531-D	1952	bezel to deck lid pad	10.00 ea.

Deck Handles

0A-7043539-B	This is die cast chrome plated. does not include lock cylinder	105.00 ea.
1A-7043530-B	1951 car, triple chrome plate with spring activated door	175.00 ea.

Deck Handle Base Pads

8A-7043531-S	1949	handle and base pad (2 pieces)	8.00 pr.
0A-7043531	1950	deck handle to deck base	8.00 pr.
1A-7043531	1951	deck base to trunk pad	12.00 ea.
BF-7043531-A	1953	deck handle pad	10.00 ea.



Most orders shipped same day!

We accept



Trunk Lid Seal

8A-7043720 1949-51 all cars
 BA-7043720 1952-59 all cars
 8M-7043720 1949-51 Merc.

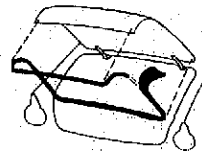

25.00 ea.
 25.00 ea.
 25.00 ea.

Trunk Lid Opening Lip Pad

This is a strip of rubber that lines the opening of the trunk so it does not cut into the trunk seal.

8A-7043734 1949-51 cars 10.00 ea.

Trunk Side Boards - Panels

BM-7045415-PR 1953-54 30.00 pr.

Trunk Lid Bumpers

BD-16754-A 1952-54 all except wagon & sedan delivery 10.00 pr.

Trunk Mats

8A-7045462 1949-50 all except convt & coupe 150.00 ea.
 8A-7645462 1949-50 convt. and coupe 120.00 ea.
 1A-7045462 1951 all except Victoria, black 110.00 ea.
 BA-7045455 1952-54 rubber mat 120.00 ea.

Trunk Lock Cylinders with 2 Keys

OA-7043505-A 1950 car 30.00 ea.
 1A-7043505 1951 car 30.00 ea.

GRILLE PARTS

Grille Assembly

Includes upper LH and RH grille bars, center LH & RH grille bars, 1 upper grille "eyebrow" molding, 1 center "8" emblem, 1 center emblem ring, LH & RH parking light housings, installing instructions, special clips and screws for assembly.

0A-8200-S 1950 1,200.00 set

Grill hardware kit

Grill hardware kit (included with the above grill)
 0A-8200-HW 1950 60.00 ea.

1949-53 CONVERTIBLE AND VICTORIA RUBBER SEALS

8A-7602626-PR	1949-50	windshield post to door seals	45.00 pr.
0A-7602626-PR	1951	windshield post to door seals convt. & Victoria	30.00 pr.
0A-7602636-PR	1949-51	shim, goes between windshield post and seals	15.00 pr.
0A-7603476	1949-51	header bow seal	32.50 ea.
8A-7621448-PR	1949-50	1950 convt. vent window seals	140.00 pr.
0A-7621448-PR	late 1950-51	convt. & Victoria vent window seals door	140.00 pr.
8A-7621450-PR	1950-51	convt. & Victoria back edge of vent window seals	20.00 pr.
BA-7021478-C		glass to frame rubber seal 1952-53	6.00 ea.
1A-7629132-PR		1951 pad for front of rear 1/4 window when rolled all the way up convt./Victoria	15.00 pr.
21A-7630106-7	1949	front of rear 1/4 window seal convt.	50.00 pr.
0A-7630106-PR	1950	front of rear 1/4 window seals convt.	40.00 pr.
1A-7630106-PR	1951	front of rear 1/4 window seals convt. and victoria	40.00 pr.
0A-7651338-PR	1950-51	header bow seal on header	50.00 pr.
8A-6451562-KIT	1949	folding top irons to door glass seals set of 6 pieces	50.00 kit
0A-6451562-KIT	1950	folding top irons to door glass seals set of 8	100.00 kit
BA-6454562-KIT	1952-54	top iron seals Convert.	350.00 kit
1A-6451562-KIT	1951	folding top irons to door seals and header seal	300.00 kit
21A-762232	1942-50	1/4 window glass to frame seal	12.00 pr.
8A-7621478	1949-50	door glass to frame glass rubber seals.	10.00 ea.
0A-7652752-PR	1950-51	seal for lower back of 1/4 window to top panel	25.00 pr.
BF-6051222-PR	1952-54	roof side rail seals Victoria	220.00pr.
1A-6051222-PR	1951	Victoria roof side rail to door seals	130.00 pr.
BA-7651330-B	1952-54	convt. header bow seal	15.00 ea.
BA-7651338-B	1952-54	convt. header seal	15.00 ea.

Most orders shipped same day!

We accept



FLOOR PAN PANELS

1949-50 Floor Pans

These panels do not include the tunnel section above the drive shaft. Made from 18 gauge sheet metal.

8A-7011135-L	1949-50	left side	130.00 ea.
8A-7011135-R	1949-50	right side	130.00 ea.
1A-7011135-LS	1951	left side	70.00 ea.
1A-7011135-RS	1951	right side	70.00 ea.
8A-7027816-PR	1949-51	1/4 patch panel 27-1/2" X 6-1/2"	60.00 pr.

1949-50 STAINLESS STEEL BODY TRIM

8A-20938-70B	R.H. door moulding coupe, tudor, convt.	60.00 ea.
8A-20938-73B	front door R.H. fordor	60.00 ea.
8A-20939-70B	L.H. coupe, tudor, convt.	60.00 ea.
8A-20939-73B	L.H. fordor front door	60.00 ea.
8A-29038-70B	R.H. 1/4 panel coupe, tudor, convt.	90.00 ea.
8A-29039-70B	L.H. 1/4 panel coupe, tudor, convt	90.00 ea.
8A-10176-7-70	1949-51 polished stainless rocker moldings	300.00 pr.

Clip Kits

8A-20000-A	1949-50	all except wagon & sedan del	110.00 kit
1A-20000-A	1951	all except wagon & sedan del	125.00 kit

1949-50 Body Moulding Clips

352362-S	Body side moulding clip for doors and quarter moulding 15-20 per side	3.00 ea.
356761-S	T-Bolt clip for rear of quarter moulding	2.50 ea.
357039-S	T-Bolt clip for front fender moulding (large one)	3.00 ea.

1951 Taillamp Spears

Chrome plated as original.

1A-29028/9	1951 cars	250.00 pr.
------------	-----------	------------

PAINT AND CHEMICALS

Engine Enamels

These are the highest quality hi-gloss engine enamels on the market.

8A-6000	1949-51 bronze	33.00 quart
FAA-6000	1952-53 orange	34.00 quart
8A-6000-S	1949-51 bronze spray can	15.00 can

Gas Tank Sealer

Stops rust, leaks and corrosion permanently. Resistant to all fuels including the new phase II oxygenated fuels. Heavily compounded with rust inhibitors. Permanently bonds to all metal or fiberglass tanks. The only sealer on the market approved for use in aircraft.

GTS-05	27.00 quart
--------	-------------

Gas Tank Etch

Will remove light buildup of rust inside of all tanks and will etch the inside of the tank leaving a gray phosphate coating. An excellent preparation for your tank before sealer with the above tank sealer. TE-01

12.00 16 oz.

Gas Preservative and Stabilizer

Prevents gum, varnish formation and corrosion in fuel tanks and fuel systems. One ounce of this product will keep three gallons of fuel fresh for at least 3 years. Contains no alcohol that attacks some metals. One quart will protect 100 gallons of fuel for three years.

FPS-01 fuel preservative 17.00 quart

Black Chassis Paint

The finest black chassis paint. Not glossy, not dull, but a very high quality semigloss paint that is the most resistant to chipping, cracking, peeling and salt.

CHPT-01 chassis black quart can 29.00 quart

Miracle Paint

A moisture cured, nonporous paint that bonds to rusted and corroded metals like no other coating. It is rock hard and will not crack, chip, or peel. Impervious to gasoline, laquer thinner, salt and most acids. Can be painted directly over rusted surfaces. Strengthened by exposure to moisture. Can be sprayed, rolled, or brushed.

MIR-PINT pint can 23.00 pint
MIR-QUART quart can 33.00 quart

Paint Stripper

This is great paint stripper in an aerosol can ready to spray.

PR-5000-A paint stripper 11.00 can

High Temperature Paint

The only finish of its type that will withstand 1800° F. Withstands salt, moisture, and virtually all weather conditions.

EMPT-15 aluminum color 27.00 pint
EMPT-14 cast iron color 27.00 pint
EMPT-16 black color 28.00 pint
EMPT-03 stainless steel 1600° F 21.00 pint

DECALS AND TAGS

DF-361	Ford Oval decal 3 1/2"	2.00 ea.
DF-362	Ford Oval decal 6 1/2"	3.00 ea.
DF-363	Ford Oval decal 9 1/2"	3.50 ea.
DF-9	1939-53 battery warranty tag	3.00 ea.
DF-129	1949-51 glove box decal	3.50 ea.
DF-130	1951-53 chrome care decal	3.00 ea.
DF-143	1949-51 air cleaner decal	4.00 ea.
DF-271	1952 glove box decal	3.00 ea.
DF-1350	1953-54 glove box decal	3.50 ea.
DF-130	1951-53 chrome care decal	3.00 ea.
DF-722	1949-51 jack instruction tag	2.50 ea.
DF-396	1952-53 jack instruction tag	2.00 ea.
DF-687	1949-51 washer bracket decal	3.50 ea.
DF-623	1952-53 washer bracket decal	3.50 ea.
DF-415	1952-53 tire stowage tag	2.50 ea.
DF-286	1952-53 front air cleaner decal	5.50 ea.
DF-287	1952-53 side air cleaner decal	5.50 ea.

Parts Tags

AT-718 wire on Ford parts tags 20.00/100

Most orders shipped same day!

We accept



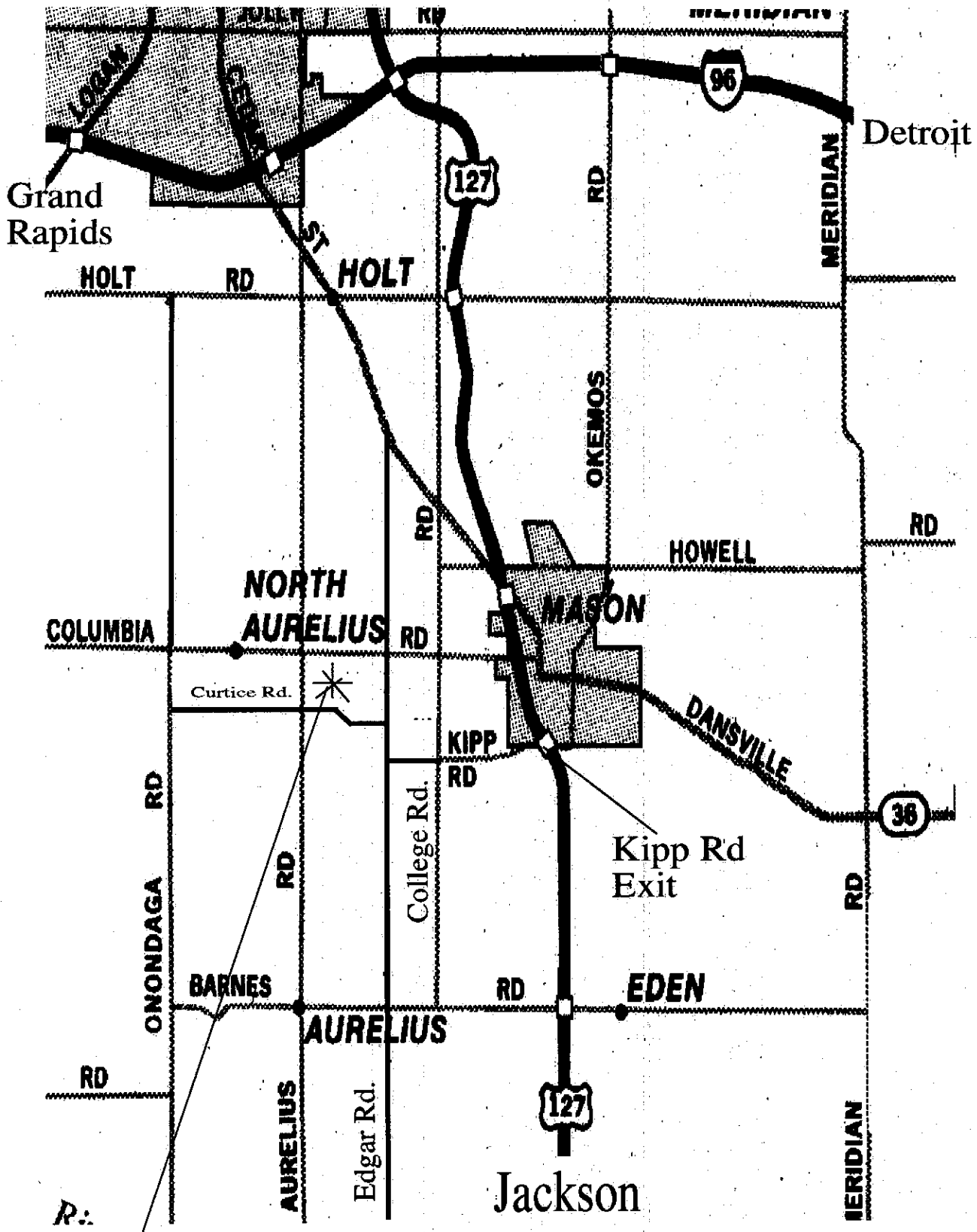

R:
 Yesteryear Ford Parts
 4322 Curtice rd.
 Mason, MI 48854

Look for the old Sinclair
 gas station sign at the drive.